

CATENE PER APPLICAZIONI SPECIALI - MAGAZZINI ROTANTI

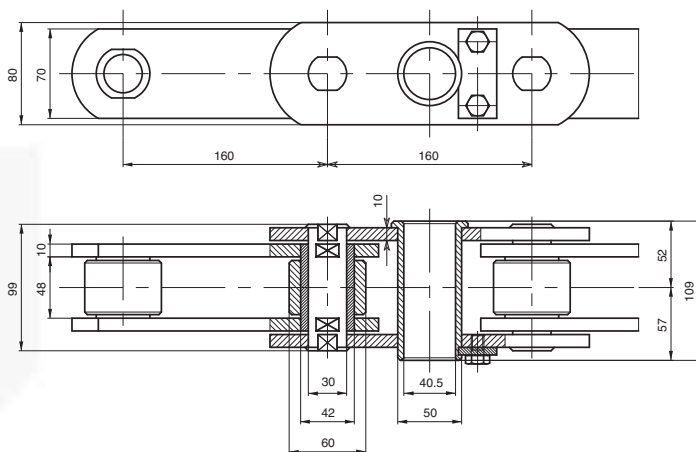

Catena P. 160x48x60 øR



Carico di rottura: 520.000 N

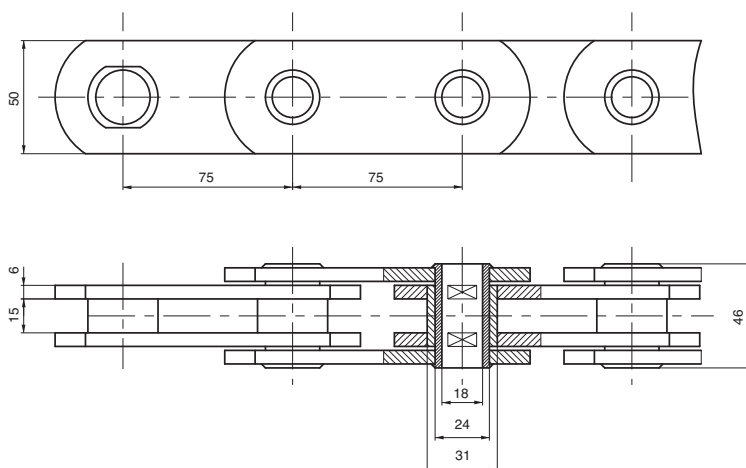

Catena P. 75x15x31 øB



Carico di rottura: 120.000 N

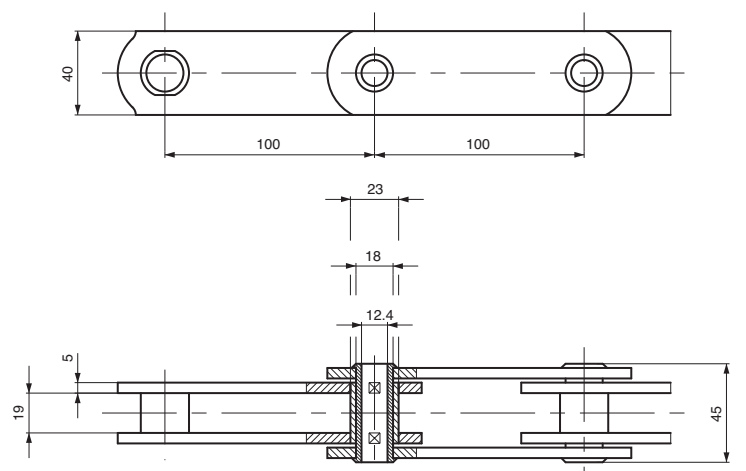

Catena P. 100x19x23 øB



Carico di rottura: 100.000 N