

## CHAINS FOR SPECIAL APPLICATIONS – FOOD OVENS

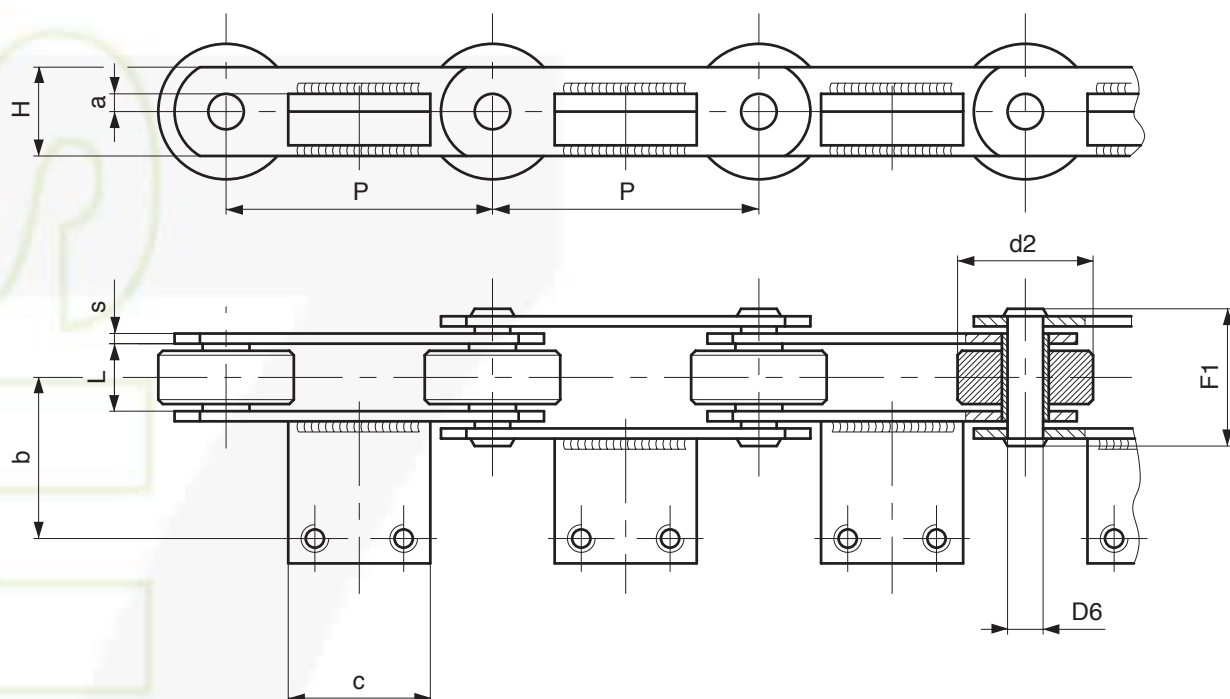

### SOLID PIN CHAINS

Chain N.	P mm	L mm	D2 mm	D6 mm	H mm	S mm	F1 mm	a mm	b mm	c mm	Breaking load N	Notes
W1596	75	22	45	12	35	4	43	17,5	50	50	100.000	Bent attachments
W2224	100	22	60	18	40	4	43,5	6	45	50	115.000	
W3636	100	22	18	12	30	4	43,5	/	/	/	64.000	Without attachments
W3030	100	25	60	14	50	5	57,5	/	/	/	150.000	Without attachments
W4983	100	36	65	22	50	6	75	4	45	60	190.000	
W2784	100	40	60	18	40	6	71	6	58	60	150.000	
W5062	100	40	60	18	40	6	71	6	58	50	150.000	
W4034	125	22	40	12	30	4	43,5	15	77	80	80.000	
W4929R	125	37	70	20	50	7	78	9	/	58	260.000	Attachments without holes
W4543	355,6	49	60	16	40	6	80,5	1	63,5	283	140.000	



# CHAINS FOR SPECIAL APPLICATIONS – FOOD OVENS

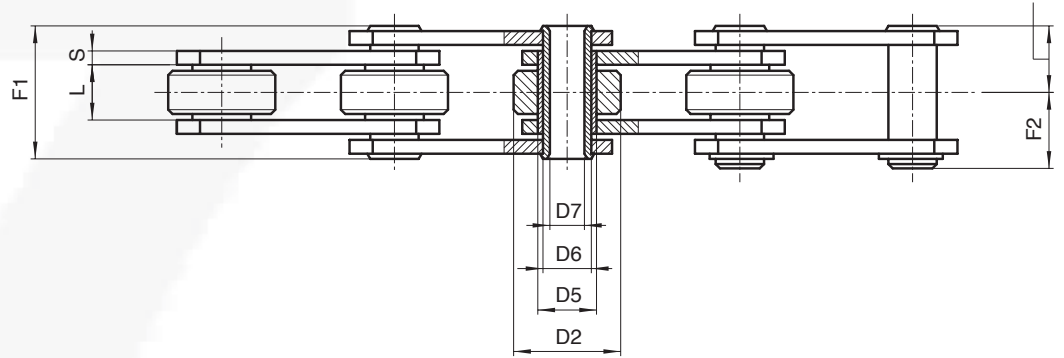
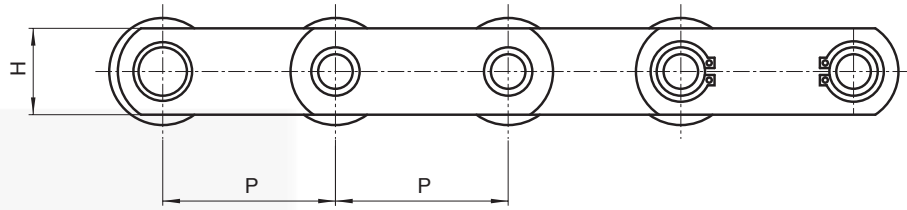

## HOLLOW PIN CHAINS

Chain N.	P mm	L mm	D2 mm	D5 mm	D6 mm	D7 mm	H mm	S mm	F1 mm	F2 mm	Breaking load N	Notes
W1368	50	11,5	31,75	17,12	10	9,7	25	3	28	17,1	40.000	**
500CRP	50	15	31	17	14	10,2	25	4	35	19,5	65.000	
W3835	75	22	45	24	18	12,4	35	4	44	27,5	120.000	***
W2467	100	25	60	26	18	10,2	40	5	51	33	135.000	
W4858	100	36	65	30,8	22	10,5	50	6	75	/	190.000	
W4445	152,4	25,4	64	31,8	25	19,5	50	7/5	56	30	150.000	

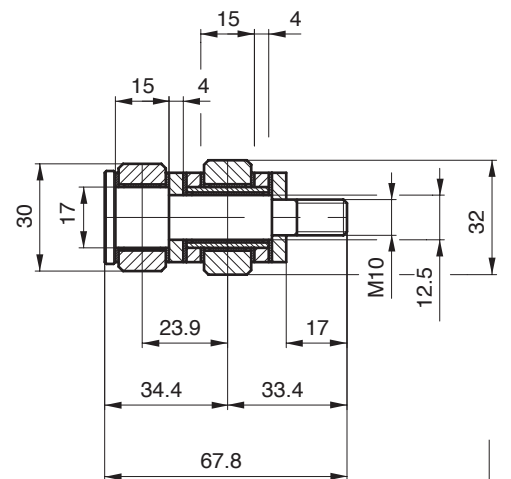
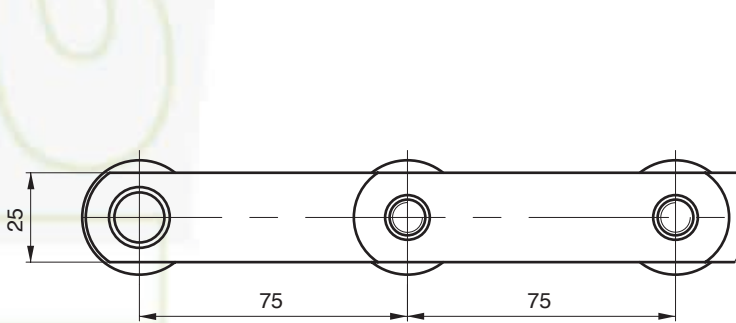

## BREAD BAKING

Chain P. 75x15x32 øR

Lubrication and maintenance free through MECASEC® (registered trade mark by P.T.F.E. Sarl)

Working temperature: 250-300°C.

\*\* Chain with solid pins and hollow pins every ...links  
 \*\*\* Hollow pins every 3 links



# CHAINS FOR SPECIAL APPLICATIONS – FOOD OVENS

BREAD BAKING

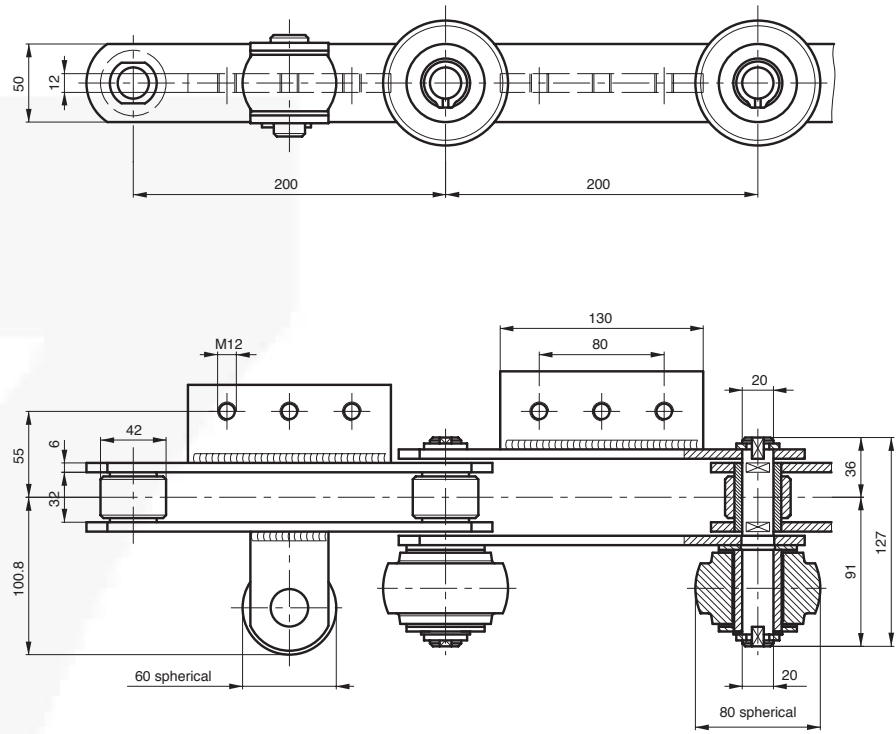

Chain P. 200x32x42 øR

Working temperature: 250-300°C

PIZZA OVENS

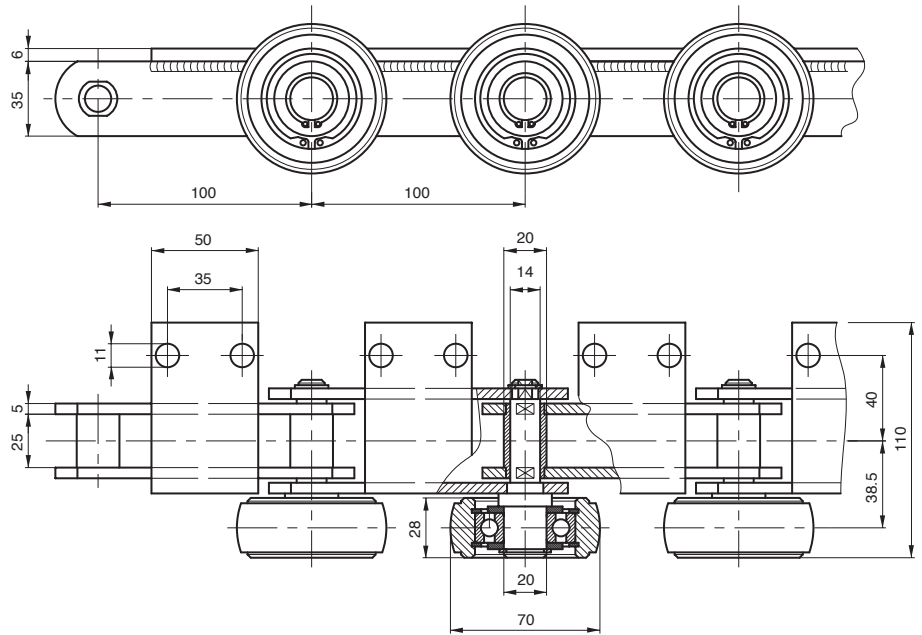

Chain P. 100x25x22 øB

Working temperature: 350-400°C

