



Chaines

CHAINES SERIE DIN 8165 (série C)



CHAINES SERIE DIN 8165

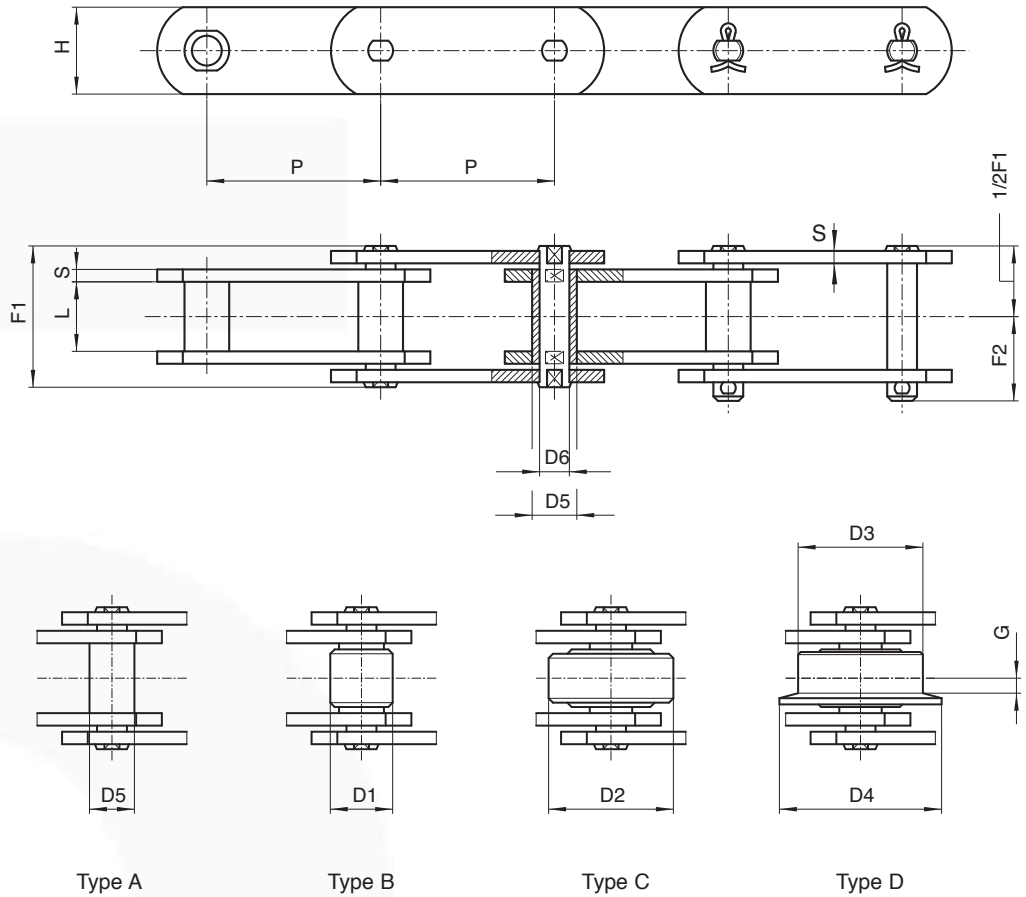

A AXES
PLEINS

DIN N.	Chaîne N.	P mm	L mm	D1 mm	D2 mm	D3 mm	D4 mm	G mm	D5 mm	D6 mm	H mm	S mm	F1 mm	F2 mm	Charge de rupture N N*	
FV40	C 42	50	18	20	32	40	50	4	15	10	25	3	36	21	42.000	47.000
"	"	63	"	"	"	"	"	"	"	"	"	"	"	"	"	"
"	"	80	"	"	"	"	"	"	"	"	"	"	"	"	"	"
"	"	100	"	"	"	"	"	"	"	"	"	"	"	"	"	"
"	"	125	"	"	"	"	"	"	"	"	"	"	"	"	"	"
FV63	C 64	63	22	26	40	50	63	5	18	12	30	4	45	26	64.000	75.000
"	"	80	"	"	"	"	"	"	"	"	"	"	"	"	"	"
"	"	100	"	"	"	"	"	"	"	"	"	"	"	"	"	"
"	"	125	"	"	"	"	"	"	"	"	"	"	"	"	"	"
"	"	160	"	"	"	"	"	"	"	"	"	"	"	"	"	"
FV90	C 100	63	25	30	48	63	78	6,5	20	14	35	5	53	30	100.000	115.000
"	"	80	"	"	"	"	"	"	"	"	"	"	"	"	"	"
"	"	100	"	"	"	"	"	"	"	"	"	"	"	"	"	"
"	"	125	"	"	"	"	"	"	"	"	"	"	"	"	"	"
"	"	160	"	"	"	"	"	"	"	"	"	"	"	"	"	"
"	"	200	"	"	"	"	"	"	"	"	"	"	"	"	"	"
"	"	250	"	"	"	"	"	"	"	"	"	"	"	"	"	"
FV112	C 120	100	30	32	55	72	90	7,5	22	16	40	6	62	35	120.000	170.000
"	"	125	"	"	"	"	"	"	"	"	"	"	"	"	"	"
"	"	160	"	"	"	"	"	"	"	"	"	"	"	"	"	"
"	"	200	"	"	"	"	"	"	"	"	"	"	"	"	"	"
"	"	250	"	"	"	"	"	"	"	"	"	"	"	"	"	"

(*) Charge de rupture avec plaques traitées

Versions alternatives:
- galets en nylon, delrin, etc.
- à axes débordants
- en acier INOX

- traitements superficiels de zingage, nickelage, etc.
- pré-étirées et présélectionnées



CHAINES SERIE DIN 8165

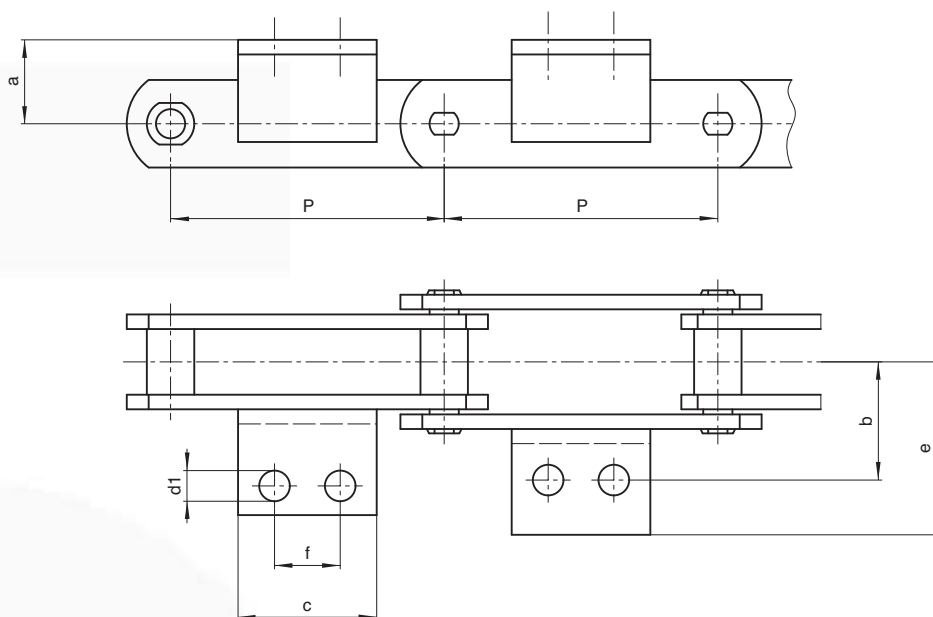

Schema du montage des attaches à la page 1.9/2

ATTACHES

DIN N.	Chaîne N.	P mm	a mm	b mm	c mm	d1 mm	e mm	f mm	Cornière mm	Poids chaîne Kg/mt				Suppl. poids attache
										type A	type B	type C	type D	
FV40	C 42	50	20	25	45	6,5	64	●	⊗	2,4	2,9	4	5,6	0,050
"	"	63	"	"	45	"	40,5	25	⊗	2	2,4	3,3	4,5	0,036
"	"	80	"	"	45	"	"	25	⊗	1,9	2,2	3	3,9	0,050
"	"	100	"	"	50	"	"	30	⊗	1,7	2	2,6	3,3	0,056
"	"	125	"	"	60	"	"	30	⊗	1,6	1,9	2,3	3	0,067
FV63	C 64	63	30	34	40	8,4	50	●	30x4	3,8	4,5	6,4	8,9	0,063
"	"	80	"	"	45	"	"	25	⊗	3,2	3,8	5,3	7,2	0,095
"	"	100	"	"	50	"	"	30	30x4	3	3,5	4,7	6,2	0,110
"	"	125	"	"	60	"	"	40	"	2,7	3	4	5,3	0,140
"	"	160	"	"	70	"	"	50	"	2,4	2,7	3,5	4,4	0,170
FV90	C 100	63	35	40	30	8,4	64	●	⊗	5,6	6,8	10	14,7	0,072
"	"	80	"	"	45	"	"	25	⊗	5,1	6	8,6	12,3	0,110
"	"	100	"	"	50	"	"	30	⊗	4,5	5,3	7,3	10,3	0,130
"	"	125	"	"	60	"	"	40	⊗	4,2	4,8	6,5	8,8	0,160
"	"	160	"	"	70	"	"	50	⊗	4	4,5	5,8	7,6	0,200
"	"	200	"	"	80	"	"	60	⊗	3,5	3,8	4,8	5,8	0,240
"	"	250	"	"	85	"	"	65	⊗	3,4	3,7	4,6	5,4	0,210
FV112	C 120	100	40	50	50	11	70	30	40x6	6,7	7,7	11,2	18,8	0,200
"	"	125	"	"	65	"	"	40	"	6	6,8	9,6	15,7	0,270
"	"	160	"	"	75	"	"	50	"	5,5	6,1	8,3	13	0,310
"	"	200	"	"	90	"	"	65	"	5,2	5,7	7,5	11,3	0,400
"	"	250	"	"	105	"	"	80	"	4,9	5,3	6,7	9,8	0,500

● attaches à 1 trou

⊗ plaque et attache en une seule pièce pliée



CHAINES SERIE DIN 8165

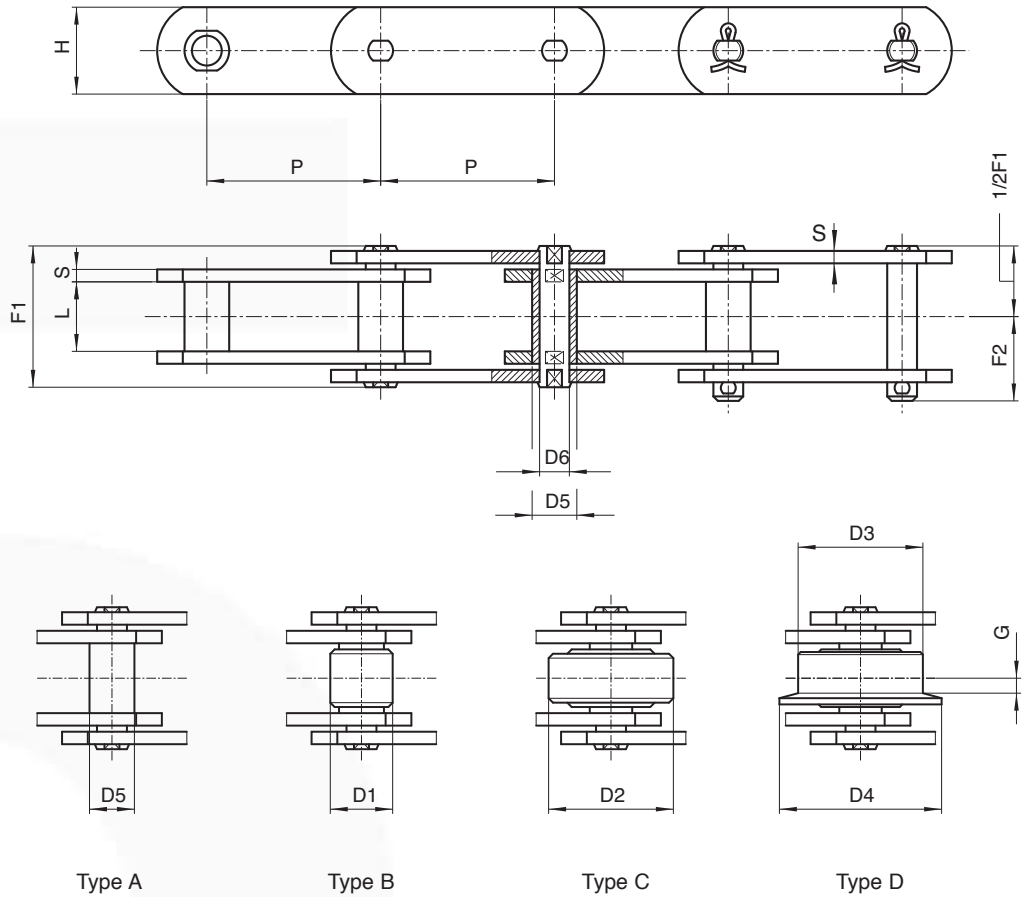

A AXES
PLEIN

DIN N.	Chaîne N.	P mm	L mm	D1 mm	D2 mm	D3 mm	D4 mm	G mm	D5 mm	D6 mm	H mm	S mm	F1 mm	F2 mm	Charge de rupture N N*	
FV140	C 145	100	35	36	60	80	100	9	26	18	45	6	67	38	145.000	180.000
"	"	125	"	"	"	"	"	"	"	"	"	"	"	"	"	"
"	"	160	"	"	"	"	"	"	"	"	"	"	"	"	"	"
"	"	200	"	"	"	"	"	"	"	"	"	"	"	"	"	"
"	"	250	"	"	"	"	"	"	"	"	"	"	"	"	"	"
FV180	C 190	125	45	42	70	100	125	13	30	20	50	8	86	49	190.000	250.000
"	"	160	"	"	"	"	"	"	"	"	"	"	"	"	"	"
"	"	200	"	"	"	"	"	"	"	"	"	"	"	"	"	"
"	"	250	"	"	"	"	"	"	"	"	"	"	"	"	"	"
"	"	315	"	"	"	"	"	"	"	"	"	"	"	"	"	"
FV250	C 275	160	55	50	80	125	155	15	36	26	60	8	97	55	275.000	300.000
"	"	200	"	"	"	"	"	"	"	"	"	"	"	"	"	"
"	"	250	"	"	"	"	"	"	"	"	"	"	"	"	"	"
"	"	315	"	"	"	"	"	"	"	"	"	"	"	"	"	"
"	"	400	"	"	"	"	"	"	"	"	"	"	"	"	"	"
FV315	C 370	160	65	60	90	140	175	18	42	30	70	10	115	67,5	370.000	480.000
"	"	200	"	"	"	"	"	"	"	"	"	"	"	"	"	"
"	"	250	"	"	"	"	"	"	"	"	"	"	"	"	"	"
"	"	315	"	"	"	"	"	"	"	"	"	"	"	"	"	"
"	"	400	"	"	"	"	"	"	"	"	"	"	"	"	"	"

(*) Charge de rupture
avec plaques traitées

Versions alternatives:

- galets en nylon, delrin, etc.
- à axes débordants
- en acier INOX
- traitements superficiels de zingage, nickelage, etc.
- pré-étirées et présélectionnées



CHAINES SERIE DIN 8165

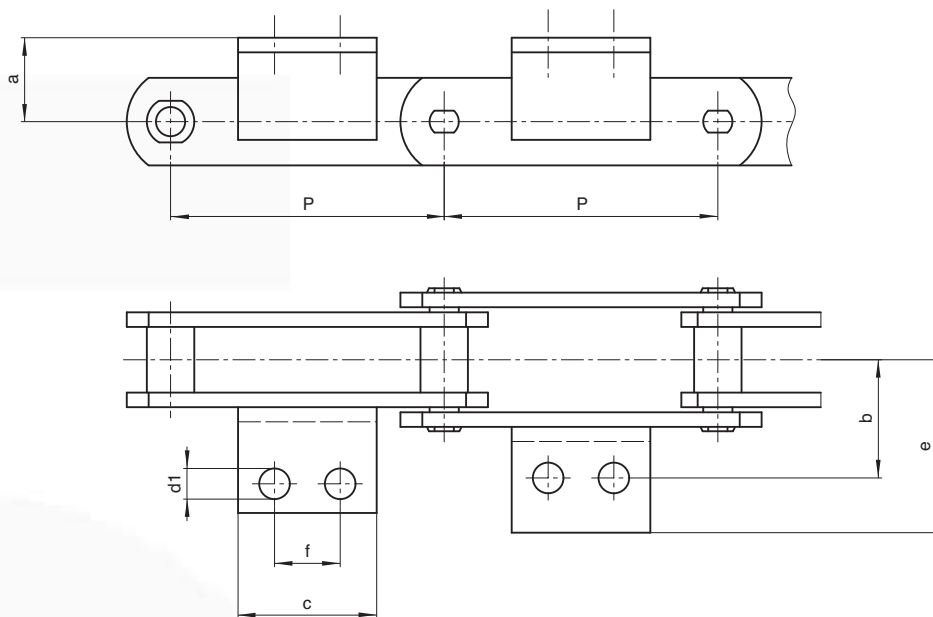

Schema du montage des attaches à la page 1.9/2

ATTACHES

DIN N.	Chaîne N.	P mm	a mm	b mm	c mm	d1 mm	e mm	f mm	Cornière mm	Poids chaîne Kg/mt				Suppl. poids attache kg
										type A	type B	type C	type D	
FV140	C 145	100	45	50	55	11	81	30	50x6	8,2	9,5	14,3	21,4	0,230
"	"	125	"	"	65	"	"	40	"	7,4	8,5	12,3	18	0,300
"	"	160	"	"	75	"	"	50	"	6,7	7,5	10,5	14,9	0,360
"	"	200	"	"	90	"	"	65	"	6	6,7	9	12,8	0,450
"	"	250	"	"	105	"	"	80	"	5,8	6,3	8,3	11	0,540
FV180	C 190	125	45	64	63	13	91	35	50x7	10,5	12,4	18,9	31,3	0,320
"	"	160	"	"	80	"	"	50	"	10,2	11,7	16,7	26,5	0,410
"	"	200	"	"	95	"	"	65	"	9,6	10,8	14,8	25,9	0,520
"	"	250	"	"	110	"	"	80	"	8,9	9,8	13	19,3	0,620
"	"	315	"	"	130	"	"	100	"	8,3	9	11,6	16,6	0,720
FV250	C 275	160	55	69	80	14	106	50	60x8	13,4	16,4	23,8	45,9	0,570
"	"	200	"	"	95	"	"	65	"	12,3	14,7	20,6	38,3	0,710
"	"	250	"	"	110	"	"	80	"	11,3	13,3	17,9	32,1	0,850
"	"	315	"	"	130	"	"	100	"	10,5	12	15,8	27	1,000
"	"	400	"	"	130	"	"	100	"	9,8	10,7	13,9	23,8	1,000
FV315	C 370	160	60	85	50	14	130	●	70x10	20,4	24,9	33,3	67,8	0,520
"	"	200	"	"	95	"	"	65	"	18,5	22,1	28,9	56,4	0,980
"	"	250	"	"	110	"	"	80	"	17	20	25,3	47,3	1,130
"	"	315	"	"	130	"	"	100	"	15,9	18,2	22,4	39,9	1,340
"	"	400	"	"	130	"	"	100	"	15	16,8	20,2	34	1,340

● attaches à 1 trou



CHAINES SERIE DIN 8165

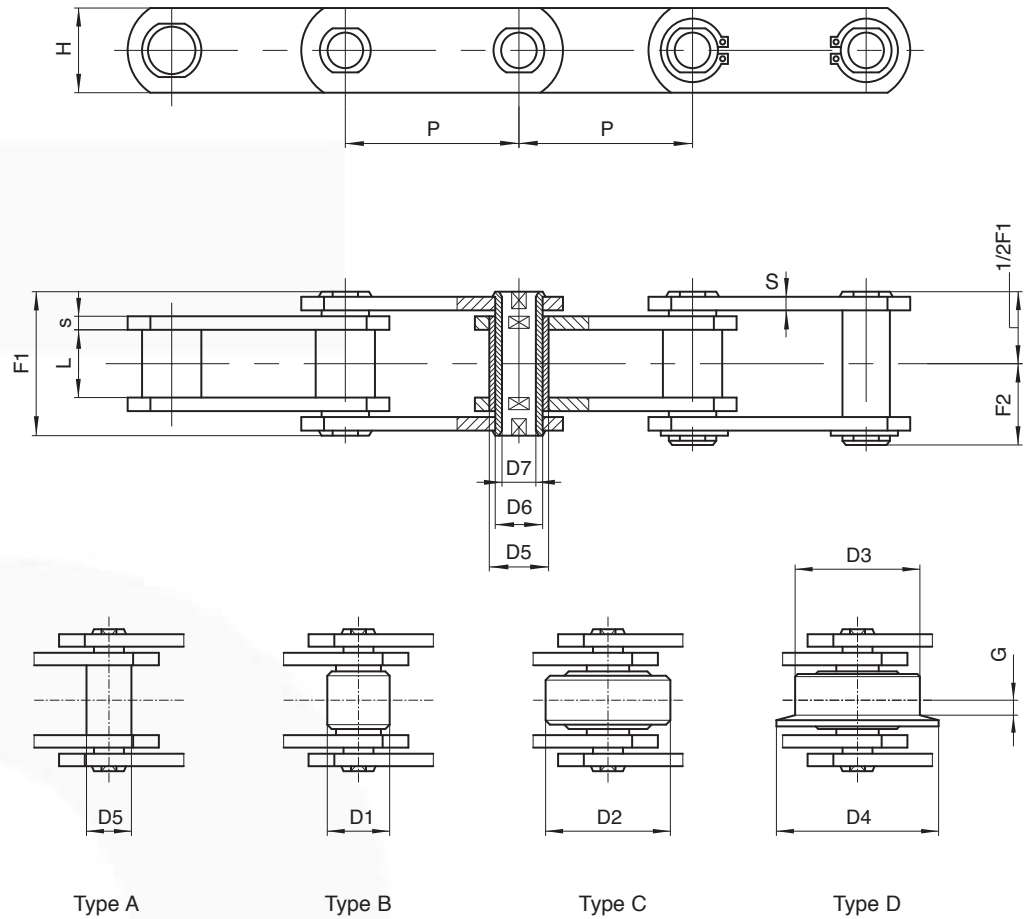

A AXES
CREUX

DIN N.	Chaîne N.	P mm	L mm	D1 mm	D2 mm	D3 mm	D4 mm	G mm	D5 mm	D6 mm	D7 mm	H mm	S mm	F1 mm	F2 mm	Charge de rupture N	Poids chaîne kg/m**
FV63	CC 46	63	22	26	40	50	63	5	18	12	8	30	4	43,5	23,75	46.000	5,7
"	"	80	"	"	"	"	"	"	"	"	"	"	"	"	"	"	4,9
"	"	100	"	"	"	"	"	"	"	"	"	"	"	"	"	"	4,3
"	"	125	"	"	"	"	"	"	"	"	"	"	"	"	"	"	3,8
"	"	160	"	"	"	"	"	"	"	"	"	"	"	"	"	"	3,4
FV90	CC 73	63	25	30	48	63	78	6,5	20	14	10	35	5	51,5	26,8	73.000	9,1
"	"	80	"	"	"	"	"	"	"	"	"	"	"	"	"	"	7,8
"	"	100	"	"	"	"	"	"	"	"	"	"	"	"	"	"	6,8
"	"	125	"	"	"	"	"	"	"	"	"	"	"	"	"	"	5,6
"	"	160	"	"	"	"	"	"	"	"	"	"	"	"	"	"	5,3
"	"	200	"	"	"	"	"	"	"	"	"	"	"	"	"	"	4,7
"	"	250	"	"	"	"	"	"	"	"	"	"	"	"	"	"	4,3
FV112	CC 90	100	30	32	55	72	90	7,5	22	16	11	40	6	62	32	90.000	10,2
"	"	125	"	"	"	"	"	"	"	"	"	"	"	"	"	"	8,9
"	"	160	"	"	"	"	"	"	"	"	"	"	"	"	"	"	7,8
"	"	200	"	"	"	"	"	"	"	"	"	"	"	"	"	"	7
"	"	250	"	"	"	"	"	"	"	"	"	"	"	"	"	"	6,3
FV140	CC 110	100	35	36	60	80	100	9	26	18	12	45	6	67	35	110.000	12,9
"	"	125	"	"	"	"	"	"	"	"	"	"	"	"	"	"	11,2
"	"	160	"	"	"	"	"	"	"	"	"	"	"	"	"	"	9,7
"	"	200	"	"	"	"	"	"	"	"	"	"	"	"	"	"	8,6
"	"	250	"	"	"	"	"	"	"	"	"	"	"	"	"	"	7,7

(**) Poids pour chaîne avec galet "type C"

- Versions alternatives:
- galets en nylon, delrin, etc.
 - en acier INOX
 - traitements superficiels de zingage, nickelage, etc.
 - pré-étirées et présélectionnées



CHAINES SERIE DIN 8165

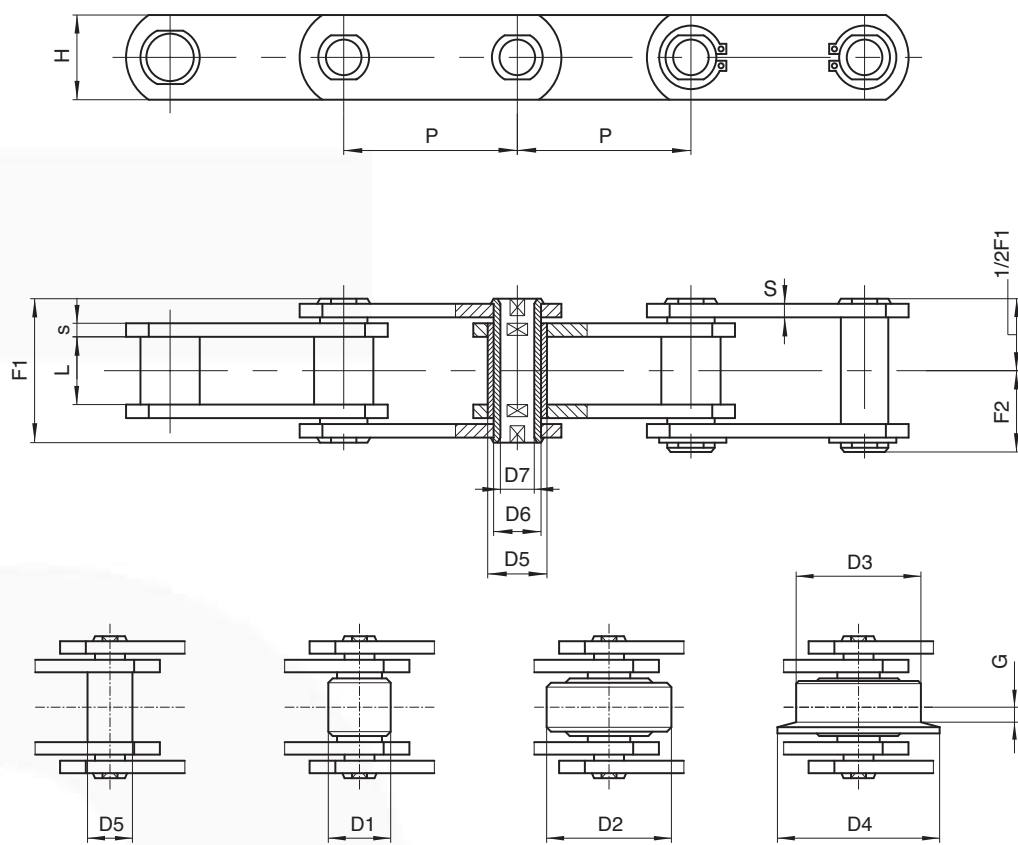

A AXES
CREUX

DIN N.	Chaîne N.	P mm	L mm	D1 mm	D2 mm	D3 mm	D4 mm	G mm	D5 mm	D6 mm	D7 mm	H mm	S mm	F1 mm	F2 mm	Charge de rupture N	Poids chaîne kg/m**
FV180	CC 145	125	45	42	70	100	125	13	30	20	14	50	8	86	45	145.000	18,2
"	"	160	"	"	"	"	"	"	"	"	"	"	"	"	"	"	15,6
"	"	200	"	"	"	"	"	"	"	"	"	"	"	"	"	"	13,8
"	"	250	"	"	"	"	"	"	"	"	"	"	"	"	"	"	12,3
"	"	315	"	"	"	"	"	"	"	"	"	"	"	"	"	"	11
FV250	CC 215	160	55	50	80	125	155	15	36	26	18	60	8	97	55	215.000	20,5
"	"	200	"	"	"	"	"	"	"	"	"	"	"	"	"	"	18
"	"	250	"	"	"	"	"	"	"	"	"	"	"	"	"	"	15,9
"	"	315	"	"	"	"	"	"	"	"	"	"	"	"	"	"	14,2
FV315	CC 295	160	65	60	90	140	175	18	42	30	20	70	10	117	63	295.000	34,1
"	"	200	"	"	"	"	"	"	"	"	"	"	"	"	"	"	29,5
"	"	250	"	"	"	"	"	"	"	"	"	"	"	"	"	"	25,8
"	"	315	"	"	"	"	"	"	"	"	"	"	"	"	"	"	22,8
"	"	400	"	"	"	"	"	"	"	"	"	"	"	"	"	"	20,2

(**) Poids pour chaîne avec galet "type C"

- Versions alternatives:
- galets en nylon, delrin, etc.
 - en acier INOX
 - traitements superficiels de zingage, nickelage, etc.
 - pré-étirées et présélectionnées



CHAINES SERIE DIN 8165

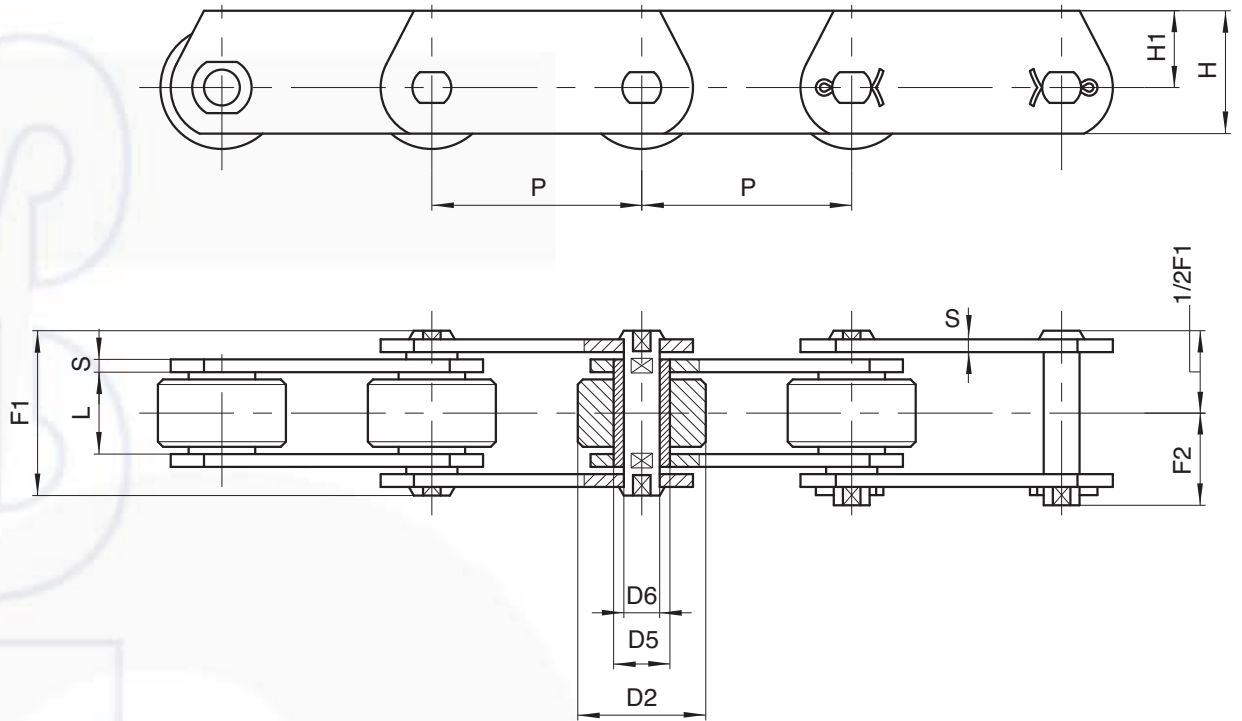

A PLAQUES DEPORTEES

DIN N.	Chaîne N.	P mm	L mm	D2 mm	D5 mm	D6 mm	H mm	H1 mm	S mm	F1 mm	F2 mm	Charge de rupture N		Poids chaîne kg/m
												N	N*	
FVT40	CE 42	50	18	32	15	10	35	22,5	3	36	21	42.000	47.000	5
"	"	63	"	"	"	"	"	"	"	"	"	"	"	4,3
"	"	80	"	"	"	"	"	"	"	"	"	"	"	3,8
"	"	100	"	"	"	"	"	"	"	"	"	"	"	3,4
"	"	125	"	"	"	"	"	"	"	"	"	"	"	3
FVT63	CE 64	63	22	40	18	12	40	25	4	45	26	64.000	75.000	7,5
"	"	80	"	"	"	"	"	"	"	"	"	"	"	6,5
"	"	100	"	"	"	"	"	"	"	"	"	"	"	5,7
"	"	125	"	"	"	"	"	"	"	"	"	"	"	5,1
"	"	160	"	"	"	"	"	"	"	"	"	"	"	4,5
FVT90	CE 100	63	25	48	20	14	45	27,5	5	53	30	100.000	115.000	11,7
"	"	80	"	"	"	"	"	"	"	"	"	"	"	10
"	"	100	"	"	"	"	"	"	"	"	"	"	"	8,7
"	"	125	"	"	"	"	"	"	"	"	"	"	"	7,7
"	"	160	"	"	"	"	"	"	"	"	"	"	"	6,8
"	"	200	"	"	"	"	"	"	"	"	"	"	"	5,8
"	"	250	"	"	"	"	"	"	"	"	"	"	"	5,4
FVT112	CE 120	100	30	55	22	16	50	30	6	62	35	120.000	170.000	12,7
"	"	125	"	"	"	"	"	"	"	"	"	"	"	11,7
"	"	160	"	"	"	"	"	"	"	"	"	"	"	9,7
"	"	200	"	"	"	"	"	"	"	"	"	"	"	8,7
"	"	250	"	"	"	"	"	"	"	"	"	"	"	8

(*) Charge de rupture avec plaques traitées

Versions alternatives:

- galets en nylon, delrin, etc.
- en acier INOX
- traitements superficiels de zingage, nickelage, etc.
- pré-étirées et présélectionnées



CHAINES SERIE DIN 8165

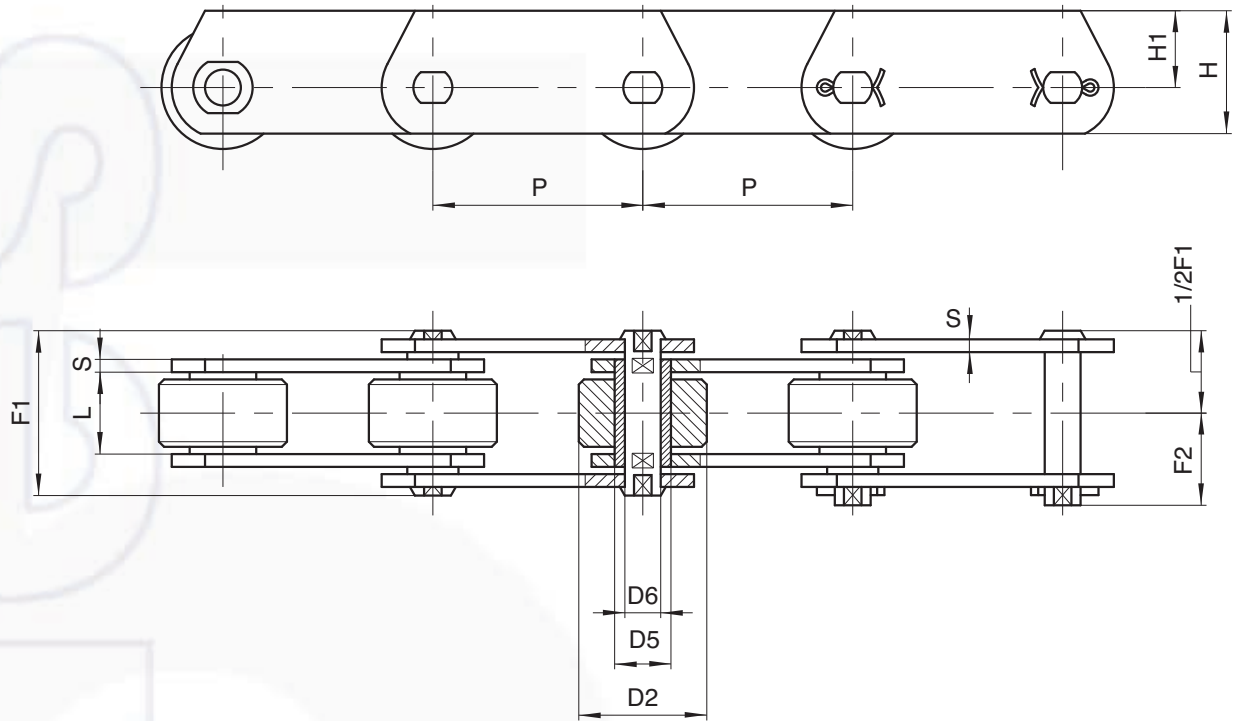

A PLAQUES
DEPORTEES

DIN N.	Chaîne N.	P mm	L mm	D2 mm	D5 mm	D6 mm	H mm	H1 mm	S mm	F1 mm	F2 mm	Charge de rupture N	Charge de rupture N*	Poids chaîne kg/m
FVT140	CE 145	100	35	60	25	18	60	37,5	6	67	38	145.000	180.000	16,8
"	"	125	"	"	"	"	"	"	"	"	"	"	"	14,6
"	"	160	"	"	"	"	"	"	"	"	"	"	"	12,6
"	"	200	"	"	"	"	"	"	"	"	"	"	"	11,3
"	"	250	"	"	"	"	"	"	"	"	"	"	"	10,1
FVT180	CE 190	125	45	70	30	20	70	45	8	86	49	190.000	250.000	24,2
"	"	160	"	"	"	"	"	"	"	"	"	"	"	20,8
"	"	200	"	"	"	"	"	"	"	"	"	"	"	18,4
"	"	250	"	"	"	"	"	"	"	"	"	"	"	16,5
"	"	315	"	"	"	"	"	"	"	"	"	"	"	14,9
FVT250	CE 275	160	55	80	36	26	80	50	8	97	55	275.000	300.000	28,2
"	"	200	"	"	"	"	"	"	"	"	"	"	"	24,5
"	"	250	"	"	"	"	"	"	"	"	"	"	"	21,7
"	"	315	"	"	"	"	"	"	"	"	"	"	"	19,3
LE 370	CE 370	160	65	90	42	30	90	55	10	115	67,5	370.000	480.000	39,9
"	"	200	"	"	"	"	"	"	"	"	"	"	"	34,8
"	"	250	"	"	"	"	"	"	"	"	"	"	"	30,6
"	"	315	"	"	"	"	"	"	"	"	"	"	"	27,3
"	"	400	"	"	"	"	"	"	"	"	"	"	"	24,5

(*) Charge de rupture avec plaques traitées

Versions alternatives:

- galets en nylon, delrin, etc.
- en acier INOX
- traitements superficiels de zingage, nickelage, etc.
- pré-étirées et présélectionnées

