

CHAINES POUR APPLICATIONS SPECIALES – INDUSTRIE DES MEUBLES

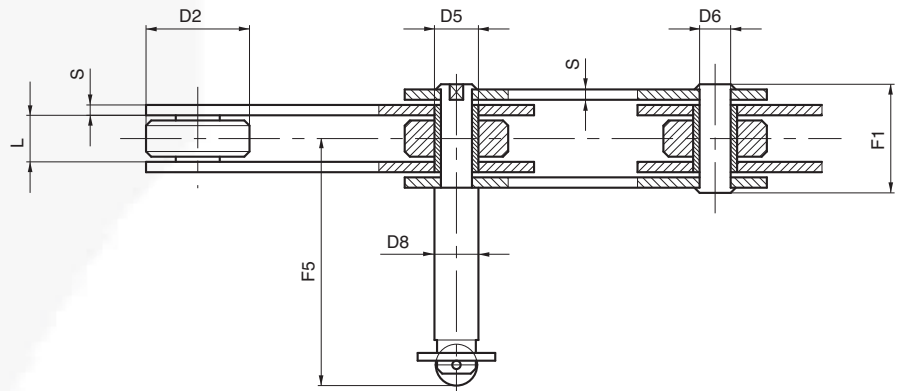

VERNISSAGE

Chaîne N.	P mm	L mm	D2 mm	D5 mm	D6 mm	D8 mm	H mm	S mm	F1 mm	F5 mm	Charge de rupture N
W2030	75	18	40	17	12	17	35	4	39	94	75.000
W1555	100	18	40	17	12	17	35	4	39	94	75.000

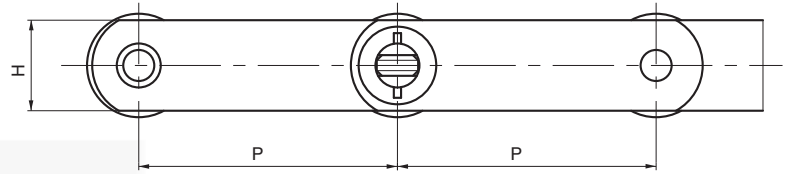
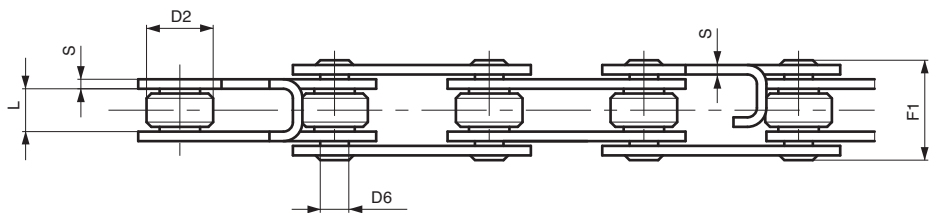
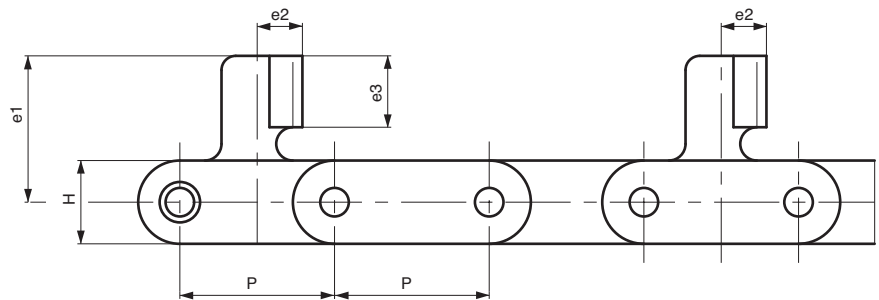

SECHAGE

Chaîne N.	P mm	L mm	D2 mm	D6 mm	H mm	S mm	F1 mm	e1 mm	e2 mm	e3 mm	Charge de rupture N
W2439	65	18	28	12	35	4	39	55,5	8	25	125.000
W2120R	75	15	40	12	35	4	36,5	55,5	8	25	125.000
W1127R03	65	18	28	12	35	4	40	61,5	12	30	125.000
W2756R	60	15	31	12	35	4	36	55,5	8	25	125.000