

CADENAS PARA APLICACIONES ESPECIALES – TÚNEL DE REFRIGERACIÓN

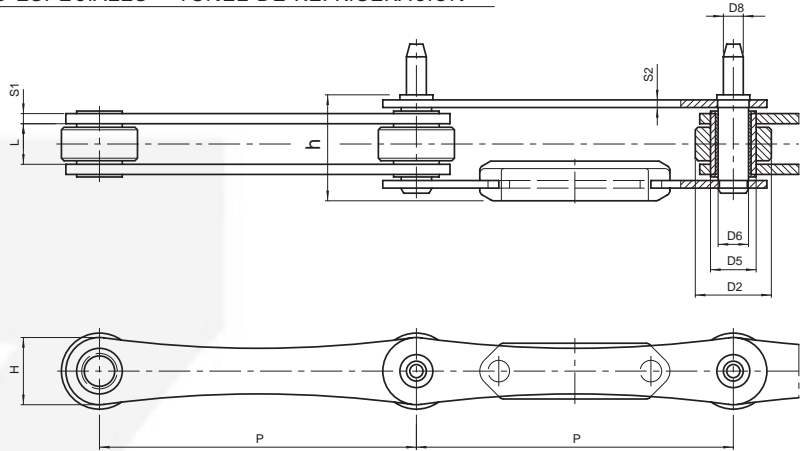

REFRIGERACION DE HELADOS

Cadena N.	P mm	L mm	D2 mm	D5 mm	D6 mm	D8 mm	H mm	S1/S2 mm	h mm	Carga de rotura N
W4577*	63,5	10	30	18	10	7,9	26,5	3	31,2	30.000
W5071*	95,25	16	30	18	11,9	9	26,5	4/3	36,8	40.000
W4530*	125	14	30	18	11,8	7,9	26,5	4/3	36,5	45.000
W4578*	125	16	30	18	11,8	7,9	26,5	4/3	39,8	40.000
W4967*	127	10	30	16	11,5	7,9	26,5	3	31,3	30.000
W4899*	150	16	30	18	11,9	7,9	26,5	4/3	42,8	40.000

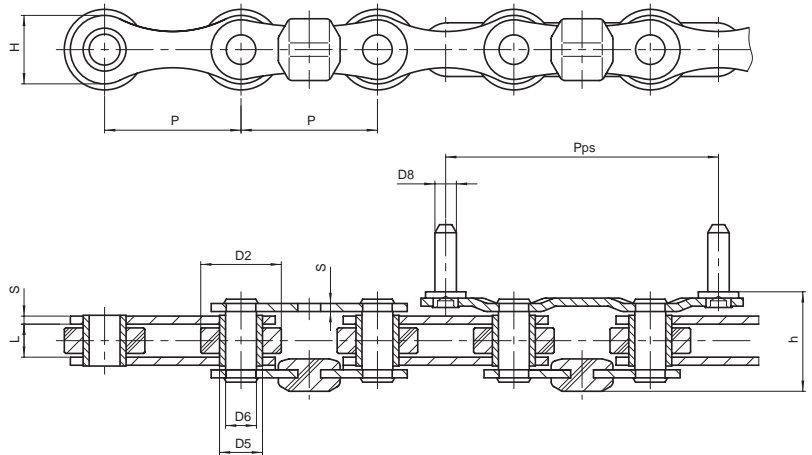

REFRIGERACION DE HELADOS

Cadena N.	P mm	L mm	D2 mm	D5 mm	D6 mm	D8 mm	H mm	S mm	h mm	Pps mm	Carga de rotura N
W4813*	50,8	10	30	16	11,5	8	25,2	3	29,3	101,6	34.000

* cadena en acero inoxidable



CADENAS PARA APLICACIONES ESPECIALES – TÚNEL DE REFRIGERACIÓN

REFRIGERACION DE HELADOS

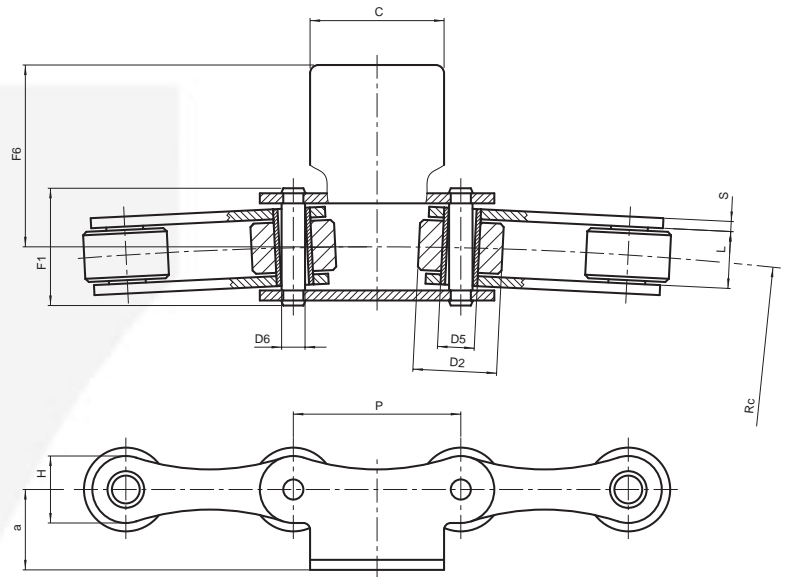

Cadena N.	P mm	L mm	D2 mm	D5 mm	D6 mm	H mm	S mm	F1 mm	a mm	c mm	F6 mm	Carga de rotura N	Notas
W1947*	50	17	25	11	7	20	3	33,5	-24	40	54	30.000	posición aleta variable

REFRIGERACION DE HELADOS

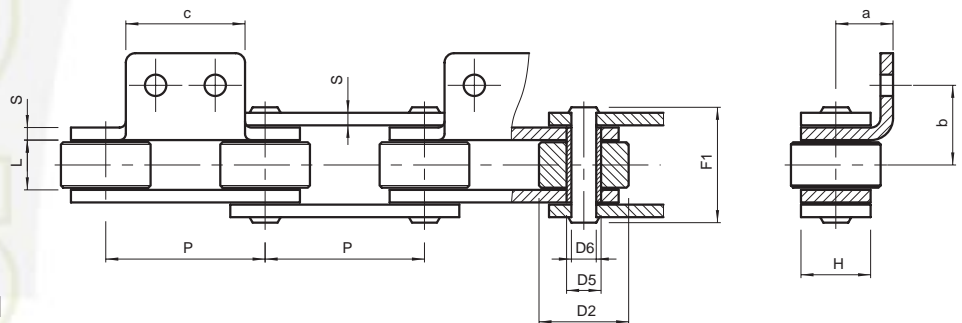

Cadena N.	P mm	L mm	D2 mm	D5 mm	D6 mm	H mm	S mm	F1 mm	a mm	b mm	c mm	Carga de rotura N
W4528ASS*	50,8	15,9	28,6	11	7,9	22,2	4	36,5	18,25	25,4	38	25.000
W4528PSS*	50,8	15,9	28,6	11	7,9	22,2	4	36,5	18,25	17,5	38	25.000

* cadena en acero inoxidable

