

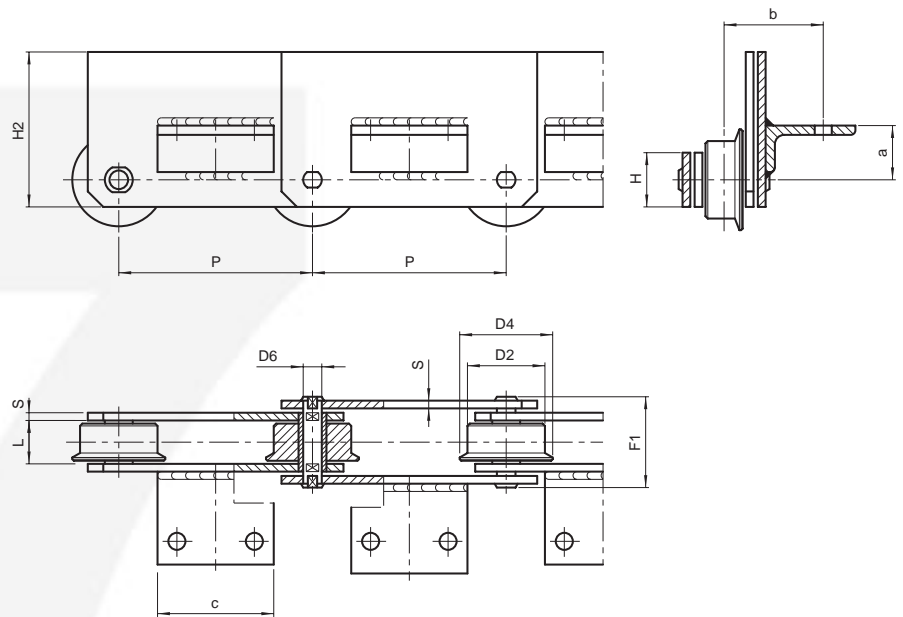

CADENAS PARA APLICACIONES ESPECIALES – RECUPERACIÓN DE PAPEL Y ELIMINACIÓN DE RESIDUOS SOLIDOS URBANOS



CON EJES  
MACIZOS

| Cadena N. | P mm | L mm | D2 mm | D4 mm | D6 mm | H mm | H2 mm | S mm | a mm | b mm | F1 mm |  Carga de rotura N | Tipo de aleta |
|-----------|------|------|-------|-------|-------|------|-------|------|------|------|-------|--|---------------|
| W1743     | 100  | 24   | 40    | /     | 12    | 35   | /     | 4    | 26   | 38,5 | 45    | 75.000   | A1-01         |
| W4563•    | 125  | 25   | 40    | /     | 14    | 35   | /     | 5    | -2,5 | 41   | 51,5  | 100.000  | A2-01         |
| W4122     | 125  | 28   | 50    | 65    | 12    | 35   | 100   | 5    | 35   | 64   | 54,5  | 80.000   | A2-01         |
| W4123•    | 125  | 28   | 50    | 65    | 12    | 35   | 100   | 5    | -5   | 64   | 54,5  | 80.000   | A2-01         |
| W4122A    | 125  | 28   | 50    | 65    | 12    | 35   | 100   | 5    | 35   | 48   | 54,5  | 80.000   | A2-01         |
| W4123A•   | 125  | 28   | 50    | 65    | 12    | 35   | 100   | 5    | -7   | 48   | 54,5  | 80.000   | A2-01         |
| W4123B*•  | 125  | 28   | 50    | 65    | 12    | 35   | 100   | 5    | -7   | 48   | 54,5  | 80.000   | A2-02         |
| W3946     | 200  | 32   | 60    | /     | 15    | 40   | 90    | 6    | /    | /    | 63    | 112.000  | sin aletas    |
| W3946R    | 200  | 32   | 60    | 75    | 15    | 40   | 90    | 6    | /    | /    | 63    | 180.000  | sin aletas    |
| W4587     | 200  | 36   | 65    | 80    | 20    | 50   | 100   | 8    | 26   | 70   | 77    | 175.000  | A2-01         |
| W4124     | 200  | 37   | 70    | 90    | 18    | 50   | 120   | 7    | 55   | 80   | 72    | 160.000  | A2-01         |
| W4125•    | 200  | 37   | 70    | 90    | 18    | 50   | 120   | 7    | -5   | 80   | 72    | 160.000  | A2-01         |
| W4639•    | 200  | 37   | 70    | 90    | 18    | 50   | 80    | 7    | -10  | 80   | 72    | 160.000  | A2-01         |
| W4124R    | 200  | 37   | 70    | 90    | 18    | 50   | 120   | 7    | 55   | 80   | 72    | 260.000  | A2-01         |
| W4125R•   | 200  | 37   | 70    | 90    | 18    | 50   | 120   | 7    | -5   | 80   | 72    | 260.000  | A2-01         |

\* Angular solo en mallas interiores  
• posición aleta bajo línea de centro

