

CADENAS PARA APLICACIONES ESPECIALES – ALMACENAMIENTO Y TRANSPORTE DE CEREALES DIN 8167

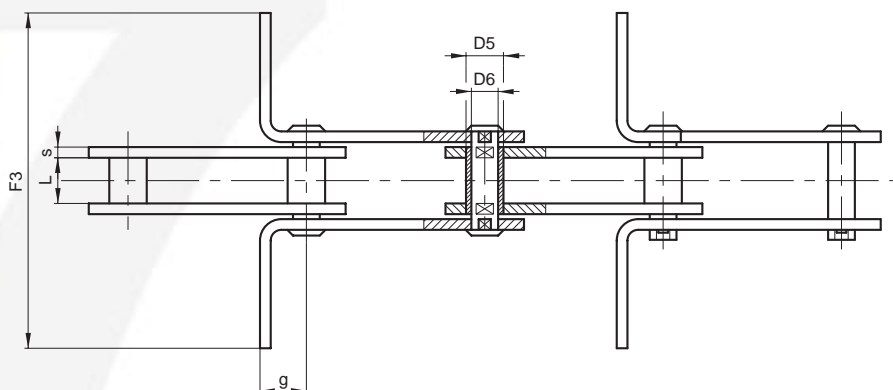
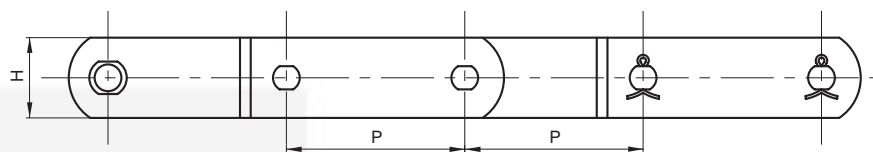

CON MALLAS RASCADORAS

Cadena N.	P mm	L mm	D5 mm	D6 mm	H mm	s mm	g mm	F3 mm	Carga de rotura N	Peso cadena kg/m ●
MR56	100	24	15	10	30	4	20	*	56.000	2,8
"	125	24	"	"	"	"	"	*	"	2,6
MR80	100	28	18	12	35	5	25	*	80.000	4,3
"	125	28	"	"	"	"	"	*	"	4
"	150	28	"	"	"	"	"	*	"	3,7
MR112	100	32	21	15	40	6	35	*	112.000	6,2
"	125	32	"	"	"	"	"	*	"	5,7
"	150	32	"	"	"	"	"	*	"	5,3
MR160	100	37	25	18	50	7	40	*	160.000	9,7
"	125	37	"	"	"	"	"	*	"	8,9
"	150	37	"	"	"	"	"	*	"	8,2
MR224	125	43	30	21	60	8	44	*	224.000	13
"	150	43	"	"	"	"	"	*	"	12
"	200	43	"	"	"	"	"	*	"	11
MR315	150	48	36	25	70	10	50	*	315.000	18,3
"	200	48	"	"	"	"	"	*	"	16,7
"	250	48	"	"	"	"	"	*	"	15,6

Versiones alternativas:

- con pasadores de aletas a uno o los dos lados
- realización agujeros
- con mallas rascadoras
- acero inoxidable

● sin mallas rascadoras

* dimensiones libres



CADENAS PARA APLICACIONES ESPECIALES – ALMACENAMIENTO Y TRANSPORTE DE CEREALES DIN 8167

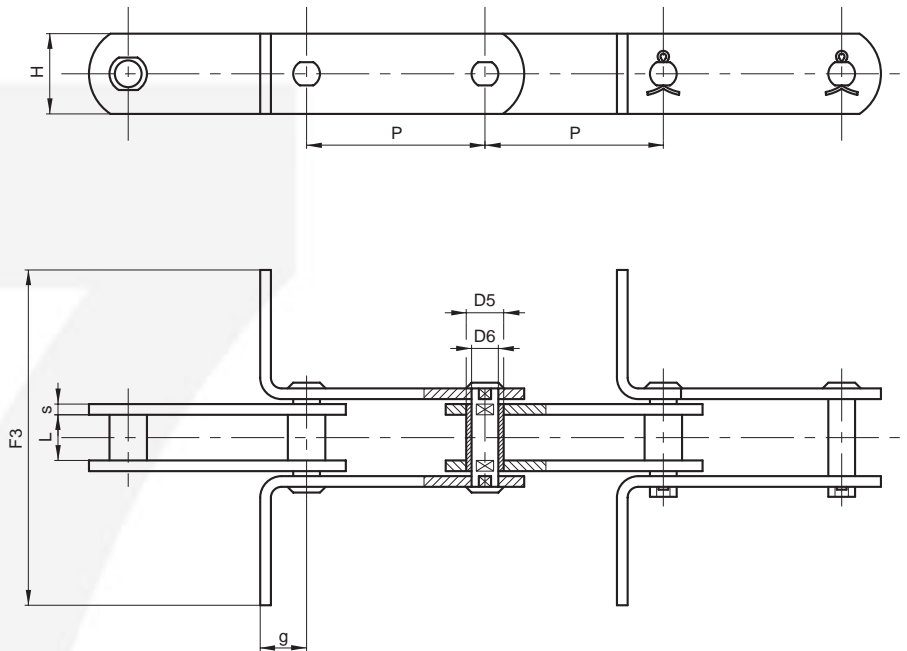

CON MALLAS RASCADORAS

DIN N.	Cadena N.	P mm	L mm	D5 mm	D6 mm	H mm	s mm	g mm	F3 mm	Carga de rotura N	Peso cadena kg/m ●
FV40	CR42	80	18	15	10	25	3	25	*	42.000	1,9
"	"	100	"	"	"	"	"	"	*	"	1,7
"	"	125	"	"	"	"	"	"	*	"	1,6
FV63	CR64	100	22	18	12	30	4	25	*	64.000	3
"	"	125	"	"	"	"	"	"	*	"	2,7
"	"	150	"	"	"	"	"	"	*	"	2,4
FV90	CR100	100	25	20	14	35	5	30	*	100.000	4,5
"	"	125	"	"	"	"	"	"	*	"	4,2
"	"	150	"	"	"	"	"	"	*	"	4
FV112	CR120	100	30	22	16	40	6	35	*	120.000	6,7
"	"	125	"	"	"	"	"	"	*	"	6
"	"	150	"	"	"	"	"	"	*	"	5,5
FV140	CR145	100	35	26	18	45	"	38	*	145.000	7,4
"	"	125	"	"	"	"	"	"	*	"	6,7
"	"	150	"	"	"	"	"	"	*	"	6
FV180	CR190	125	45	30	20	50	8	44	*	190.000	10,5
"	"	150	"	"	"	"	"	"	*	"	10,2
"	"	200	"	"	"	"	"	"	*	"	9,6
FV250	CR275	125	55	36	26	60	"	50	*	275.000	13,4
"	"	150	"	"	"	"	"	"	*	"	12,3
"	"	200	"	"	"	"	"	"	*	"	11,3

Versiones alternativas:
 - con pasadores de aletas a uno o los dos lados
 - realización agujeros
 - con mallas rascadoras
 - acero inoxidable

● sin mallas rascadoras
 * dimensiones libres

