

# CHAINS FOR SPECIAL APPLICATIONS – PROVER INDUSTRY

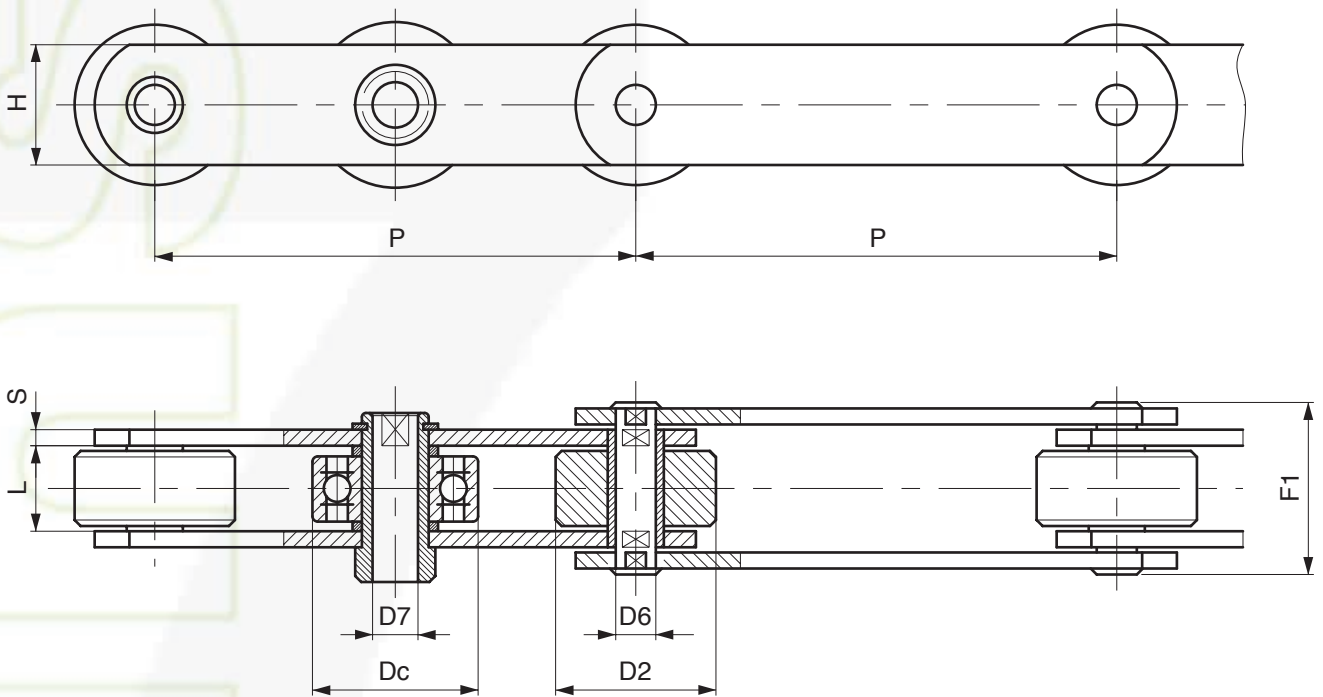

## SWINGING TRAYS CONVEYORS

Chain N.	P mm	L mm	D2 mm	D6 mm	D7 mm	Dc mm	H mm	S mm	F1 mm	Breaking load N	Notes
W3248	80	28	52	18	12	52	35/40	5	55	80.000	Ball bearing roller
W3513	80	28	52	12	14,2	52	35/40	5	55	80.000	Ball bearing roller
W4976	140	32	30	21	15	47	40	6	63	170.000	
W4949	152,4	26	60	33	27	62	50	7/5	58	200.000	
W3729	160	32	60	21	17	62	40/45	6	63	140.000	
W4751	160	35	36	25	17	62	45	6	65	180.000	
W3247	180	32	60	21	15	62	40/45	6	63	112.000	
W2498	180	36	70	30	20	72	60	8	77	300.000	
W3064	180	43	70	30	21	72	60	8	84	300.000	
W4937	200	26	60	33	27	62	50	7/5	58	200.000	
W2340	200	36	70	30	20	72	60	8	77	300.000	