

CHAINS FOR SPECIAL APPLICATIONS – FOOD INDUSTRY

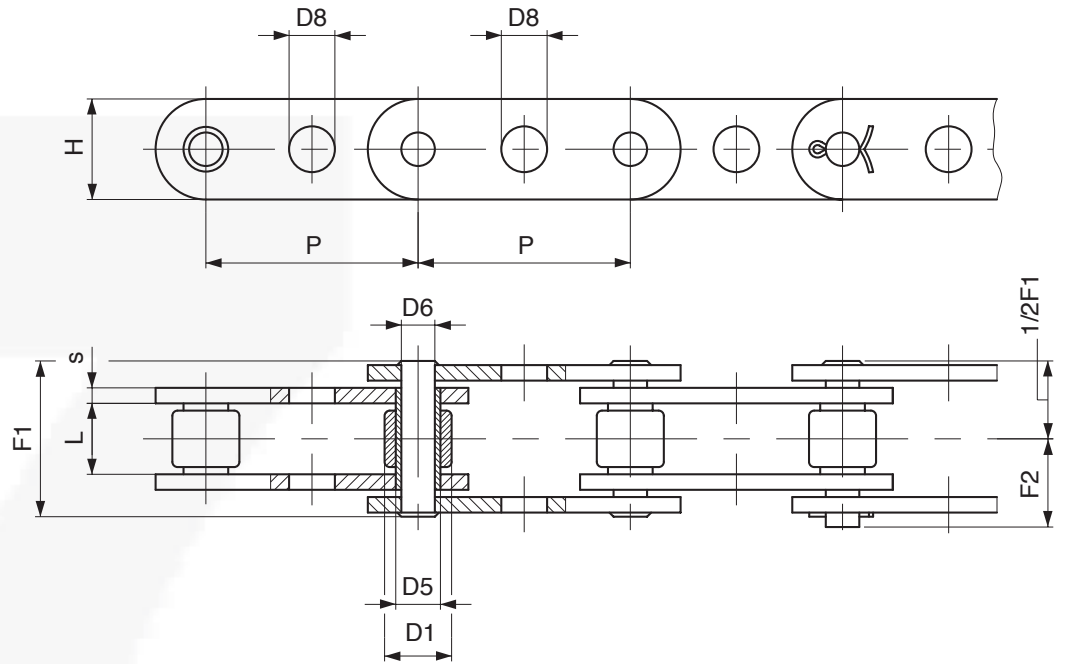

ELECTRONIC GRADING MACHINE

Chain N.	P mm	L mm	D1 mm	D5 mm	D6 mm	D8 mm	H mm	S mm	F1 mm	F2 mm	Breaking load N	Chain weight kg/m
❖ C2060HFFPT	38,1	12,7	11,91	8,4	6	8,2	18	3	29,2	18	38.000	1,6
❖ W3609...	44,45	12,7	11,91	8,4	6	8,1	18	3	29,2	18	38.000	1,4
❖ W4376...	50	11,7	12,07	8,3	6	8,1	17	2,5	27	16	20.000	1,2

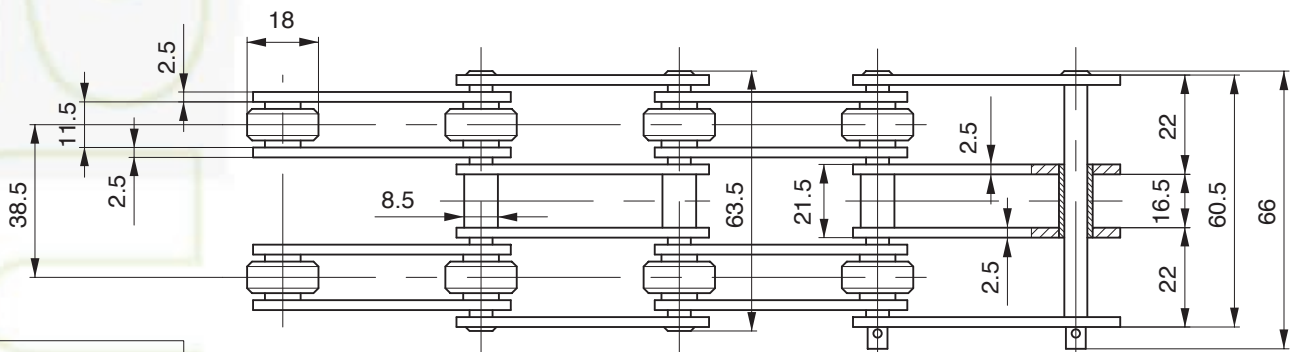
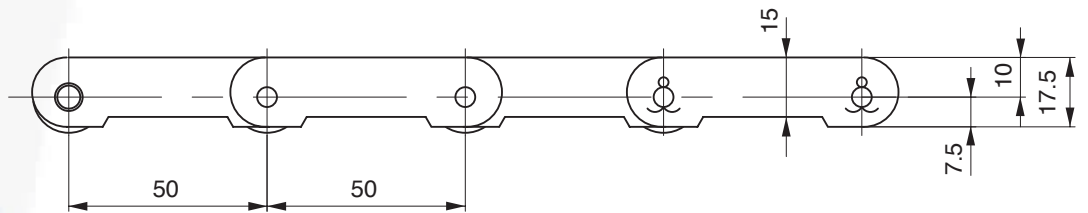

TRIPLE chain P. 50x11,5x18ØR ZINC PLATED
cod: 350TZ

Breaking load: 32.000 N

❖ zinc plated execution



CHAINS FOR SPECIAL APPLICATIONS – FOOD INDUSTRY

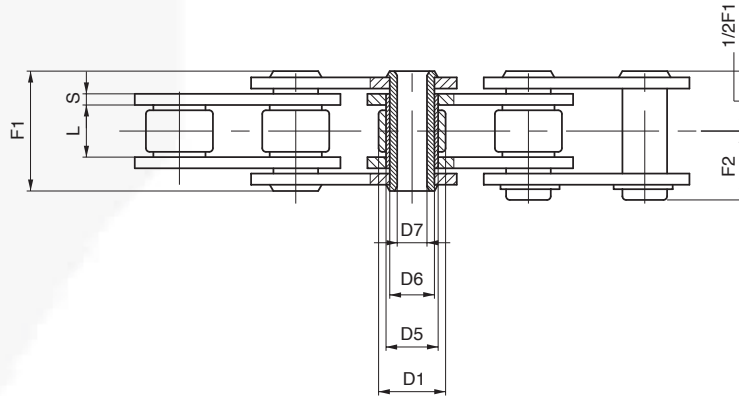
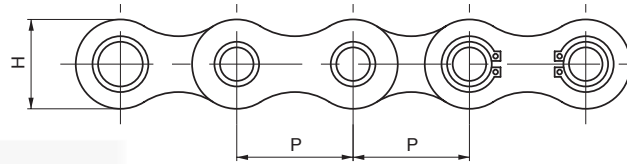

Layout of attachments
on page 1.9/2

HOLLOW PIN CHAINS

Chain N.	P mm	L mm	D1 mm	D5 mm	D6 mm	D7 mm	H mm	S mm	F1 mm	F2 mm	Breaking load N	Chain weight kg/m
❖ 3520Z	35	16	20	17	14	10,4	26	2,5	31	16,7	25.000	2,2
3520RZ	35	16	20	17	14	10,4	26	2,5	31	16,7	40.000	2,2
❖ 4020Z	40	16	20	17	14	10,4	30	2,5	31	16,7	25.000	2,3

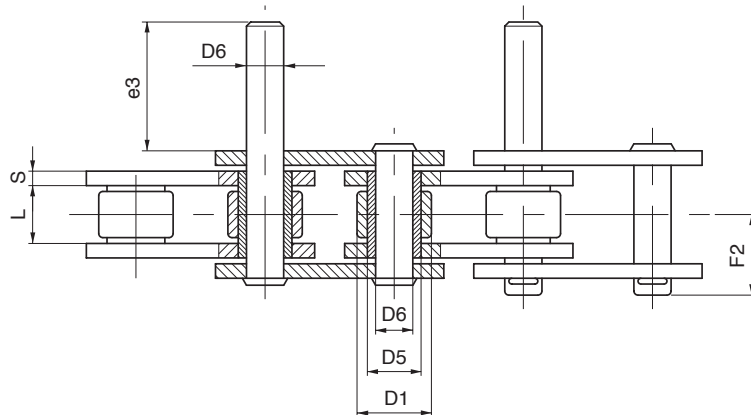
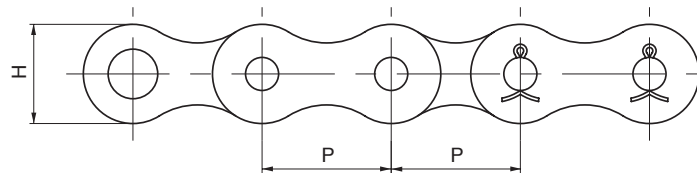

WITH EXTENDED PINS

Chain N.	P mm	L mm	D1 mm	D5 mm	D6 mm	H mm	S mm	F2 mm	F6 mm	e3 mm	Breaking load N	Chain weight kg/m
❖ 3521Z	35	16	20	13	10	26	2,5	50,5	67,5	35	35.000	2,8
▲ W3033...	38,1	12,7	11,91	8,5	10	18	3	17,5	80,0	35	38.000	2,2
▲ W3109...	38,1	12,7	22,23	8,5	10	18	3	17,5	80,0	35	38.000	2,3

❖ zinc plated execution

▲ zinc plated or nickel plated execution

