

CHAINES POUR APPLICATIONS SPECIALES – STOCKAGE-MANUTENTION DES CEREALES DIN 8167

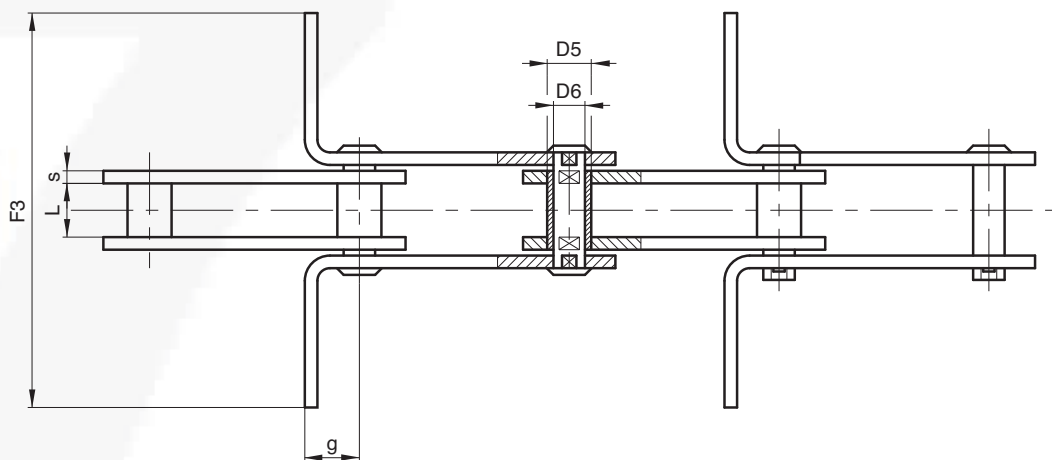
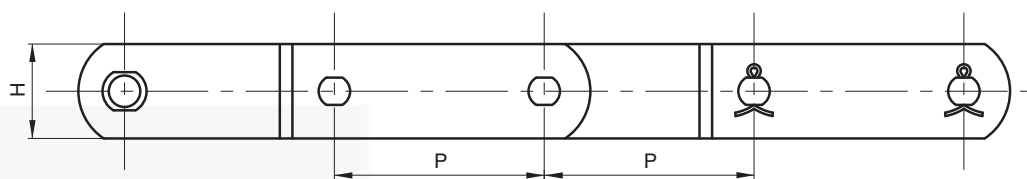

CHAINES A RACLETTES

Chaîne N.	P mm	L mm	D5 mm	D6 mm	H mm	s mm	g mm	F3 mm	Charge de rupture N	Poids chaîne kg/m ●
MR56	100	24	15	10	30	4	20	⊗	56.000	2,8
"	125	24	"	"	"	"	"	⊗	"	2,6
MR80	100	28	18	12	35	5	25	⊗	80.000	4,3
"	125	28	"	"	"	"	"	⊗	"	4
"	150	28	"	"	"	"	"	⊗	"	3,7
MR112	100	32	21	15	40	6	35	⊗	112.000	6,2
"	125	32	"	"	"	"	"	⊗	"	5,7
"	150	32	"	"	"	"	"	⊗	"	5,3
MR160	100	37	25	18	50	7	40	⊗	160.000	9,7
"	125	37	"	"	"	"	"	⊗	"	8,9
"	150	37	"	"	"	"	"	⊗	"	8,2
MR224	125	43	30	21	60	8	44	⊗	224.000	13
"	150	43	"	"	"	"	"	⊗	"	12
"	200	43	"	"	"	"	"	⊗	"	11
MR315	150	48	36	25	70	10	50	⊗	315.000	18,3
"	200	48	"	"	"	"	"	⊗	"	16,7
"	250	48	"	"	"	"	"	⊗	"	15,6

Versions alternatives:
 - goupillées d'un ou des 2 côtés
 - avec raclettes percées
 - en inox

● sans raclettes
 ⊗ dimensions libres



CHAINES POUR APPLICATIONS SPECIALES – STOCKAGE-MANUTENTION DES CEREALES DIN 8165

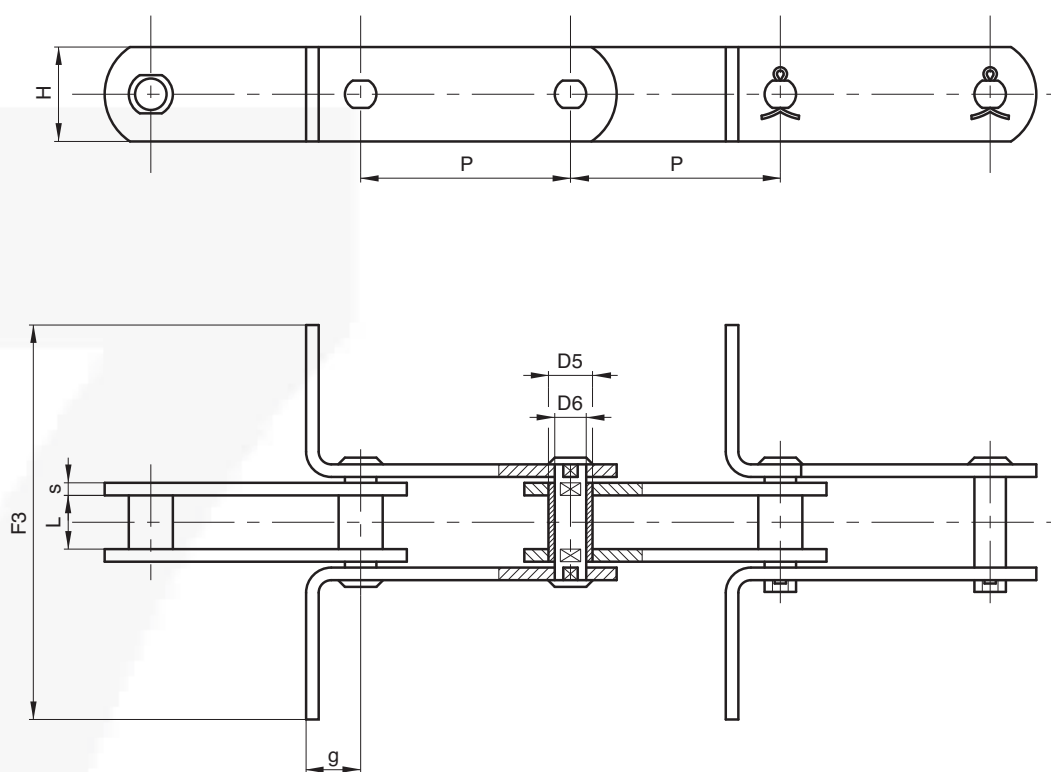

CHAINES A RACLETTES

DIN N.	Chaîne N.	P mm	L mm	D5 mm	D6 mm	H mm	s mm	g mm	F3 mm	Charge de rupture N	Poids chaîne kg/m ●
FV40	CR42	80	18	15	10	25	3	25	⊗	42.000	1,9
"	"	100	"	"	"	"	"	"	⊗	"	1,7
"	"	125	"	"	"	"	"	"	⊗	"	1,6
FV63	CR64	100	22	18	12	30	4	25	⊗	64.000	3
"	"	125	"	"	"	"	"	"	⊗	"	2,7
"	"	150	"	"	"	"	"	"	⊗	"	2,4
FV90	CR100	100	25	20	14	35	5	30	⊗	100.000	4,5
"	"	125	"	"	"	"	"	"	⊗	"	4,2
"	"	150	"	"	"	"	"	"	⊗	"	4
FV112	CR120	100	30	22	16	40	6	35	⊗	120.000	6,7
"	"	125	"	"	"	"	"	"	⊗	"	6
"	"	150	"	"	"	"	"	"	⊗	"	5,5
FV140	CR145	100	35	26	18	45	"	38	⊗	145.000	7,4
"	"	125	"	"	"	"	"	"	⊗	"	6,7
"	"	150	"	"	"	"	"	"	⊗	"	6
FV180	CR190	125	45	30	20	50	8	44	⊗	190.000	10,5
"	"	150	"	"	"	"	"	"	⊗	"	10,2
"	"	200	"	"	"	"	"	"	⊗	"	9,6
FV250	CR275	125	55	36	26	60	"	50	⊗	275.000	13,4
"	"	150	"	"	"	"	"	"	⊗	"	12,3
"	"	200	"	"	"	"	"	"	⊗	"	11,3

Versions alternatives:
 - goupillées d'un ou des 2 côtés
 - avec raclettes percées
 - en inox

● sans raclettes
 ⊗ dimensions libres

