

# CADENAS PARA APLICACIONES ESPECIALES – INDUSTRIA DE EMBOTELLADO

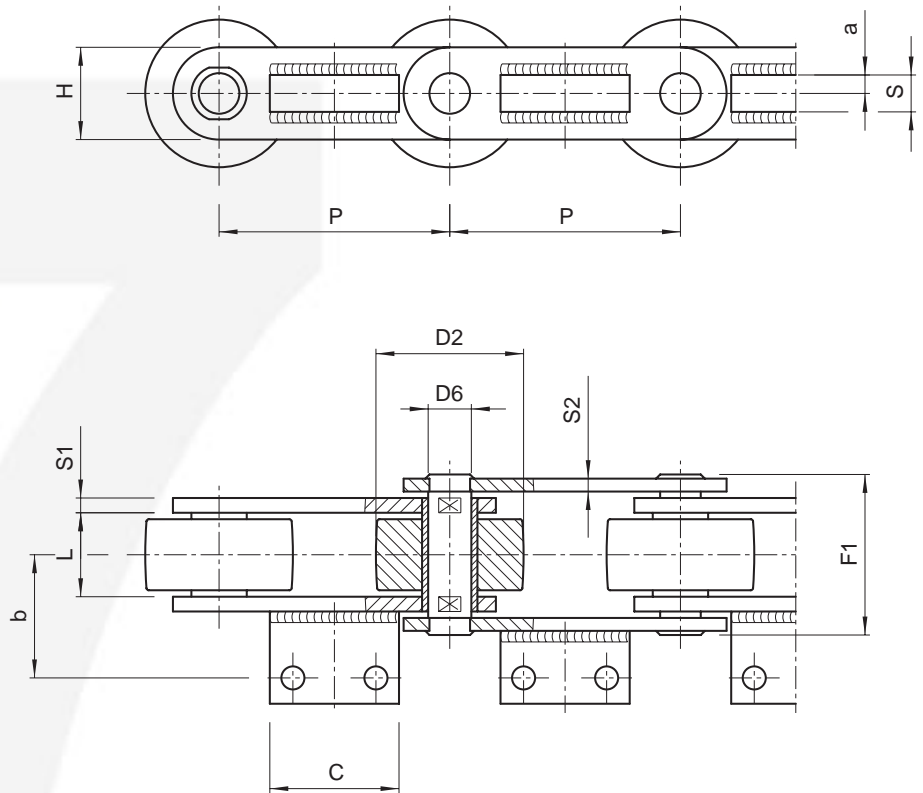

## LAVADO DE BOTELLAS

Cadena N.	P mm	L mm	D2 mm	D6 mm	H mm	S1/S2 mm	F1 mm	a mm	b mm	c mm	s mm	Carga de rotura N	Tipo de aleta
W4020CR*	125	42	80	22	50	7/8	79	10	65	70	20	200.000	A2-01
W3820	135	25	75	22	50	5/7	54	25	47	75	5	156.000	A2-01
W4021CR*	140	42	80	22	50	7/8	79	10	65	80	20	200.000	A2-01
W3834	150	25	80	22	50	5/7	54	30	48	80	5	156.000	A2-01
W3819	150	37	90	18	50	7	70	25	52	80	15	160.000	A2-01
W4022CR*	150	42	80	22	50	7/8	79	10	65	90	20	200.000	A2-01
W4502	160	43	85	21	60	8	84	0	64,5	80	20	300.000	A2-01
W4023CR*	173	42	80	22	50	7/8	79	10	65	90	20	200.000	A2-01
W4024CR*	203,2	42	80	22	50	7/8	79	10	65	90	20	200.000	A2-01

\* soluciones alternativas con L = 32 mm

