

# KETTEN FÜR SONDERANWENDUNGEN – ZIEGEL- UND BETONSTEININDUSTRIE

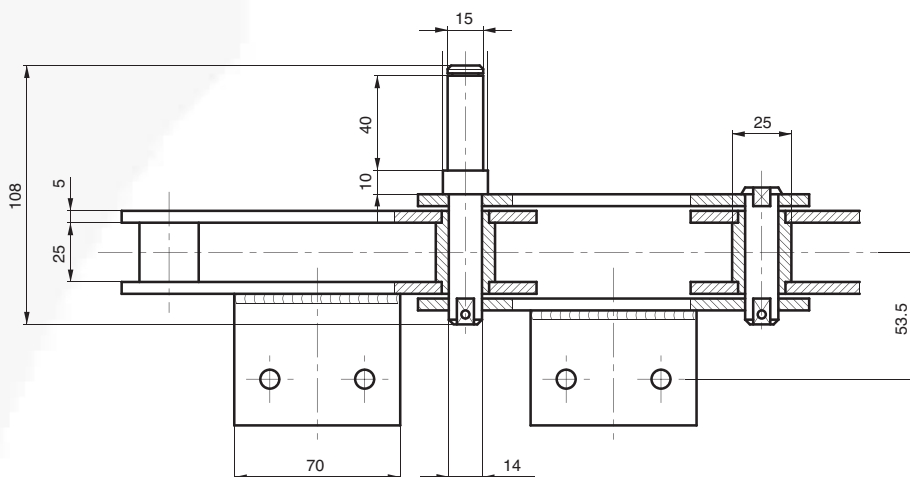

Kette Tlg. 125x25x25  $\varnothing$ B

 Bruchkraft: 100.000 N

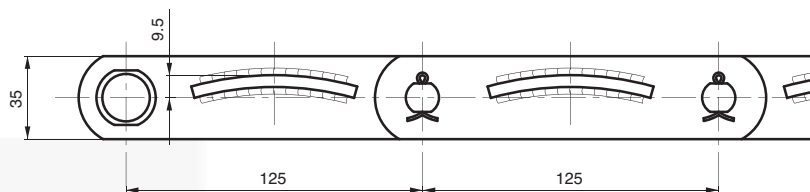
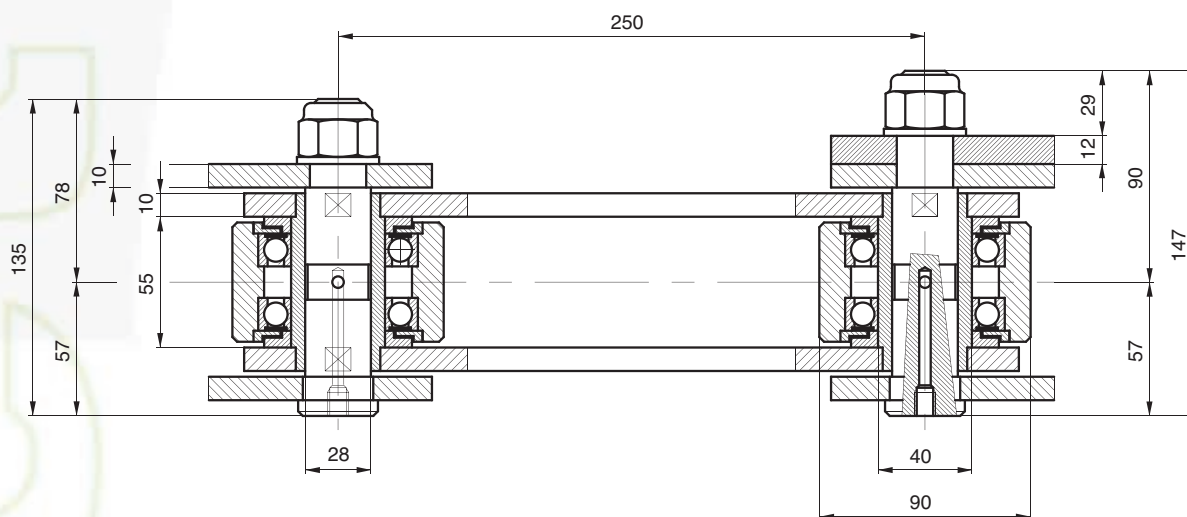

SCHAUFELRAD-  
BAGGER

Kette Tlg. 250x55x90  $\varnothing$ R

 Bruchkraft: 500.000 N

