

# CADENAS PARA APLICACIONES ESPECIALES – ALMACENES ROTATIVOS

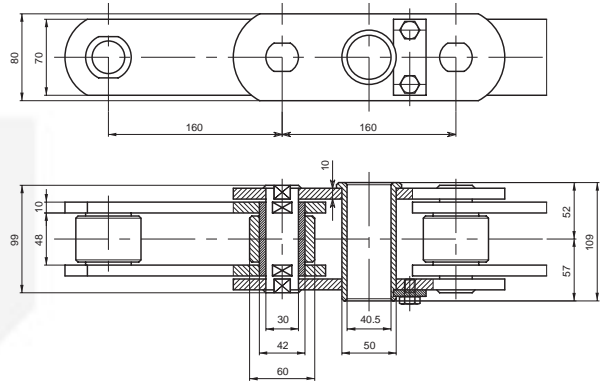

Cadena P. 160x48x60 øR



Carga de rotura: 520.000 N

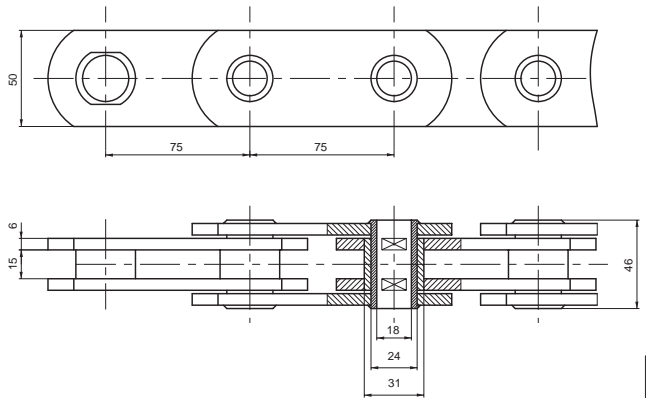

Cadena P. 75x15x31 øB



Carga de rotura: 120.000 N

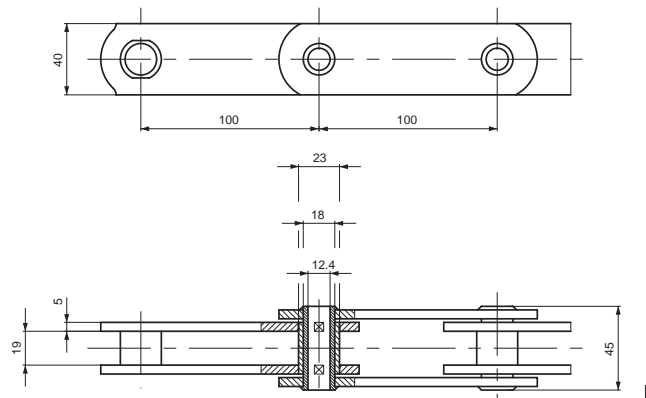

Cadena P. 100x19x23 øB



Carga de rotura: 100.000 N

